



Basic Education
KwaZulu-Natal Department of Education
REPUBLIC OF SOUTH AFRICA

PHYSICAL SCIENCES P1 (PHYSICS)

COMMON TEST

JUNE 2016

**NATIONAL SENIOR
CERTIFICATE**

GRADE 10

MARKS: 100

TIME: 2 hours

This question paper consists of 8 pages and 1 data sheet.

INSTRUCTIONS AND INFORMATION

1. Write your name in the appropriate spaces on the ANSWER BOOK.
2. Answer ALL the questions in the ANSWER BOOK.
3. You may use a non-programmable calculator.
4. You may use appropriate mathematical instruments.
5. Number the answers correctly according to the numbering system used in this question paper.
6. You are advised to use the attached data sheets.
7. Give brief motivations, discussions, et cetera where required.
8. Round off your answers to a minimum of 2 decimal places.

QUESTION 1: MULTIPLE CHOICE QUESTIONS

Four possible options are provided as answers to the following questions. Each question has only ONE correct answer. Write ONLY letters (A – D) next to the question number (1.1 – 1.6) in the ANSWER BOOK.

- 1.1 The diagram below shows a wave moving in a slinky in the direction as shown. P represents a ribbon fastened to the slinky spring.

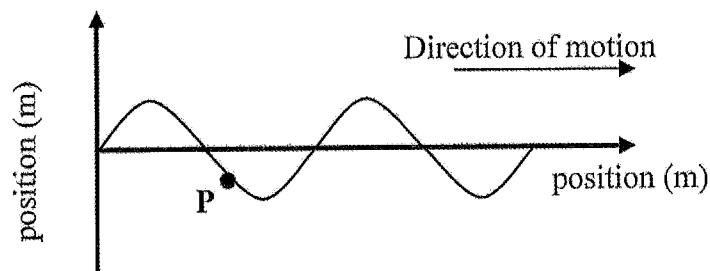

In which direction is **P** moving?

- A To the right
 B Upward
 C Downward
 D To the left (2)
- 1.2 When the loudness of a musical note increases, then the ...
 A wavelength decreases.
 B frequency increases.
 C amplitude increases.
 D period decreases. (2)
- 1.3 A Perspex rod is charged negatively by rubbing it with woollen cloth. During the charging process...
 A electrons are transferred from the Perspex rod to the woollen cloth.
 B electrons are transferred from the woollen cloth to the Perspex.
 C protons are transferred from the Perspex rod to the woollen cloth
 D protons are transferred from the woollen cloth to the Perspex rod. (2)

1.4 In the following circuit the bulbs are identical. Which switches must be closed in order for bulb B only to light up?

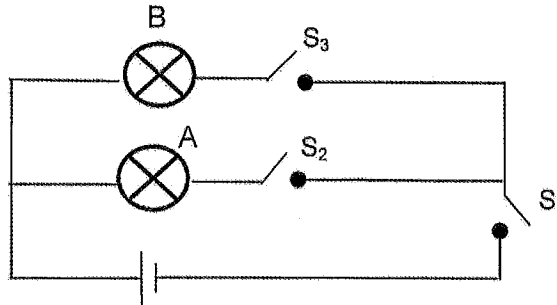

A S_1, S_2 and S_3

B S_1 and S_2

C S_2 and S_3

D S_1 and S_3

(2)

The following 2 questions refer to the circuit diagram below:

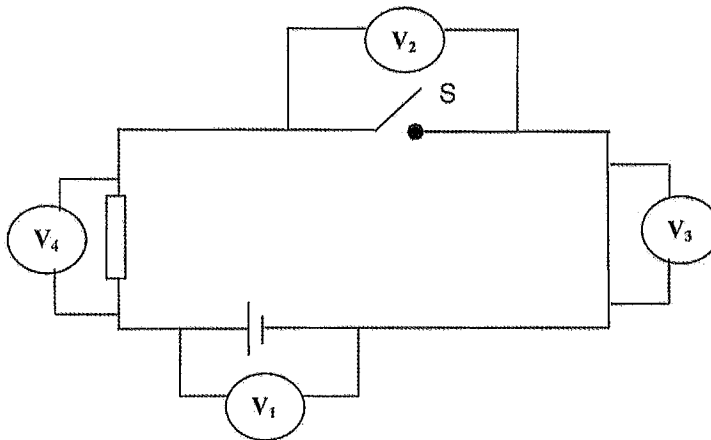

1.5 When switch S is open, the reading on V_1 is 2V. Which statement is correct with respect to the readings on the other voltmeters?

	V_2 (V)	V_3 (V)	V_4 (V)
A	2	2	2
B	0	0	2
C	2	0	0
D	0	0	0

(2)

1.6 Switch S is now closed. The new readings on the voltmeters will be ...

	V_2 (V)	V_3 (V)	V_4 (V)
A	0	0	2
B	$\frac{2}{3}$	$\frac{2}{3}$	$\frac{2}{3}$
C	2	2	2
D	2	0	2

(2)
 $2 \times 6 = [12]$

QUESTION 2

- 2.1 The diagram below shows the pattern obtained for a sound wave of frequency of 485 Hz.

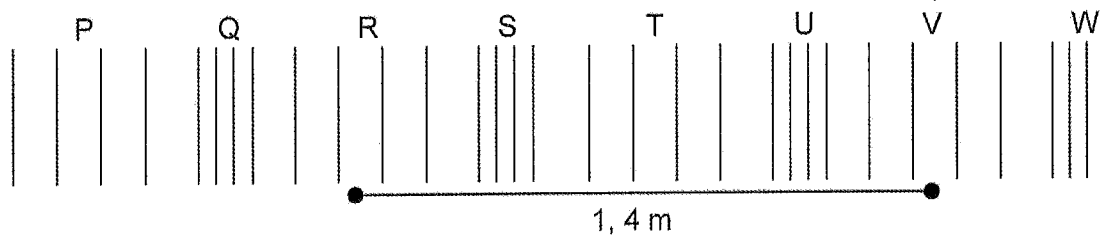

- 2.1.1 Is the wave represented above a longitudinal or a transverse wave? Give a reason for your answer. (3)
- 2.1.2 Write down the letters that represent TWO consecutive points on the wave which are in phase. (1)
- 2.1.3 Draw the corresponding particle position versus time graph of the wave shown above. Indicate ALL the corresponding points (**P** to **W**) on the graph. (4)
- 2.1.4 What is meant by the statement: "frequency of the wave is 485 Hz?" (2)
- 2.1.5 Calculate the speed of the wave. (3)
- 2.2 Two pulses A and B are moving at the same speed along a light string. Pulse A is moving to the right with amplitude of +12 mm and pulse B is moving to the left with an amplitude of +8 mm. The pulses meet at point C. (Assume that all energy is conserved).
- 2.2.1 What is a pulse? (1)
- 2.2.2 State the principle of superposition of waves (2)
- 2.2.3 What is the amplitude of the resultant pulse at point C? (1)
- 2.2.4 What type of interference takes place at point C? (1)
- 2.2.5 Make a labelled sketch of the pulses after they pass point C. (2)

[20]

QUESTION 3

The electromagnetic (EM) spectrum includes, amongst others, radio waves, ultraviolet light, gamma rays and x-rays.

- 3.1 List 2 properties of EM waves. (2)
- 3.2 Arrange the above 4 waves in order of decreasing wavelength. (2)
- 3.3 Which of the above EM waves has the greatest penetrating ability? Give a reason. (3)
- 3.4 A photon of ultraviolet light has $1,33 \times 10^{-18} \text{J}$ of energy associated with it. Calculate the wavelength of this wave. (5)

[12]**QUESTION 4**

- 4.1 A grade 10 learner performed an experiment to determine the direction and pattern of the magnetic field around a bar magnet. Based on her results, she drew the following diagram in which the north and south poles of the magnet are correctly labelled.

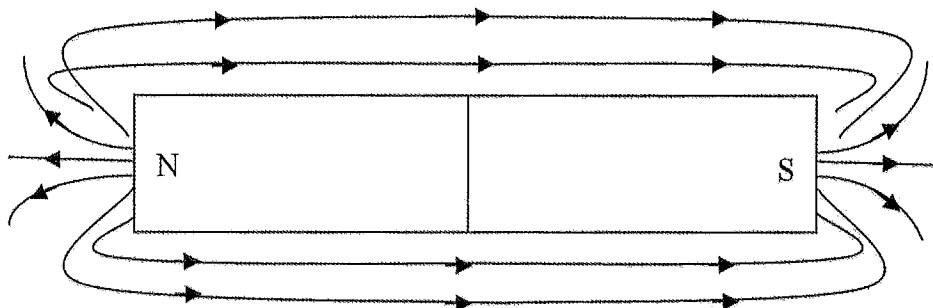

- 4.1.1 What is a magnetic field? (2)
- 4.1.2 Identify THREE mistakes that the learner made in the drawing. (3)
- 4.1.3 Name the device that the learner used to determine the direction of the magnetic field. (1)
- 4.1.4 Suppose the magnet used by the learner is broken into two pieces without losing its magnetic properties. Draw a sketch of the two pieces and label the resulting magnetic poles. (2)
- 4.2 People that are living near the north pole of Earth can see the northern lights (Aurora Borealis). It is a spectacular display of coloured light in the sky. Briefly describe why it is visible near the geographical north pole of Earth and how it is formed. (4)

[12]

QUESTION 5

5.1 State the Law of conservation of charge. (2)

5.2 Three identical spheres, mounted on insulated stands, carry charges of $+20\ \mu\text{C}$; $-8\ \mu\text{C}$ and neutral, as shown.

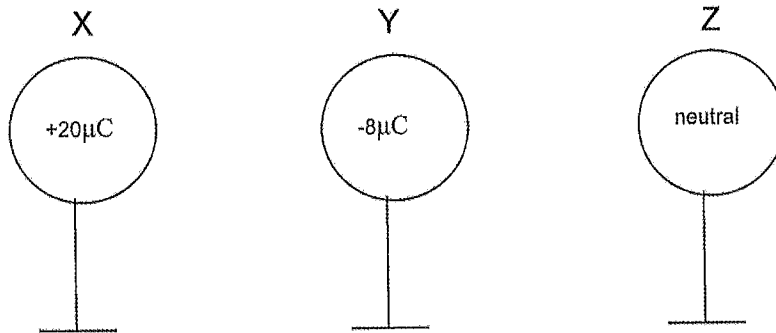

5.2.1 Calculate the final charge on each sphere when X touches Y and then X touches Z. (5)

5.2.2 How many electrons were transferred when X touched Y? (3)

5.2.3 It is observed that when X touched Y the spheres repelled each other. Explain this observation with reference to the nature of the charges. (2)

5.2.4 Is it possible to have the final charges on the spheres as follows?

- X = $+10\ \mu\text{C}$
- Y = $+2\ \mu\text{C}$
- Z = $-6\ \mu\text{C}$.

Explain. (3)

5.2.5 Another identical neutral sphere is now placed to the right of Z after X touched Z. (These two spheres do not touch).

In what direction will this sphere experience a force?
(Choose from: **TOWARDS Z** or **AWAY FROM Z**)

Explain. (3)

[18]

S
ARDE
s^{-2}
$m \cdot s^{-1}$
$J \cdot s$
kg
C

$+\frac{1}{2}a\Delta t^2$
$\left(\frac{v_1}{2}\right)\Delta t$

(2)

(2)

(2)

e? (2)

conducting

(

)

(3)

(2)

(1)

(

)

(2)

or in (4)

arge (3)

sistor

ME) (3)

RKS: [26] [100]



Basic Education

KwaZulu-Natal Department of Basic Education
REPUBLIC OF SOUTH AFRICA

PHYSICAL SCIENCES P1 (PHYSICS)

MEMORANDUM

JUNE 2016

**NATIONAL SENIOR
CERTIFICATE**

GRADE 10

MARKS: 100

TIME: 2 hours

This memorandum consists of 6 pages.

QUESTION 1

- 1.1 C✓✓
- 1.2 C✓✓
- 1.3 B✓✓
- 1.4 D✓✓
- 1.5 C✓✓
- 1.6 A✓✓

QUESTION 2

[12]

2.1.1 transverse wave ✓

Rarefactions ✓ and compressions ✓ occur.

(3)

2.1.2 ANY TWO OF: P, R, T, V e.g. P & R ✓

OR

ANY TWO OF: Q, S, U, W e.g. Q & S ✓

(1)

2.1.3

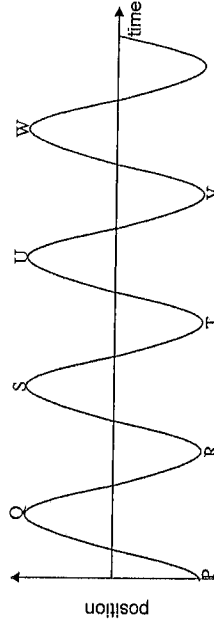

Marking criteria	
Position on the y-axis and time on the x-axis	✓
Shape of the graph	✓
Positions of compressions Q, S, U, W.	✓
Positions of rarefactions P, R, T, V.	✓

(4)

2.1.4 485 complete cycles pass a point in one second ✓✓ (2)

$$2.1.5 \ v = f \lambda \checkmark \\ = 485 \times 0,5 \times 1,4 \checkmark \\ = 339,5 \text{ m/s} \checkmark \quad (3)$$

2.2.1 single disturbance in a medium ✓ (1)

2.2.2 when 2 waves moving in a medium meet, the resulting amplitude is determined by the algebraic sum of the 2 amplitudes ✓✓ (2)

2.2.3 +20 mm ✓ (1)

2.2.4 constructive interference ✓ (1)

2.2.5

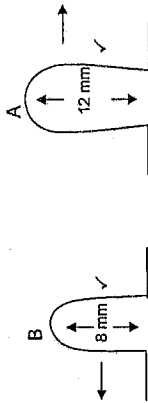

[20]

QUESTION 3

3.1 They are transverse waves
They travel at $3 \times 10^8 \text{ m.s}^{-1}$

They can be transmitted in vacuum. (any two) ✓✓ (2)

3.2 radio waves \Rightarrow ultra violet light \Rightarrow x-rays \Rightarrow gamma rays ✓✓ (2)

3.3 Gamma rays ✓
It has greatest frequency ✓✓ (3)

$$3.4 \ \frac{E = hc}{\lambda} \checkmark \\ 1,33 \times 10^{-18} = \frac{6,63 \times 10^{-34} \cdot 3 \times 10^8}{\lambda} \\ \lambda = 1,495 \times 10^{-7} \text{ m} \checkmark \quad (5)$$

[12]

QUESTION 4

4.1.1 Region around the magnet where another magnet/ magnetic substance experiences a force. ✓✓ (2)

4.1.2 Some magnetic field lines do not touch the magnet ✓
Incorrect direction at South Pole. ✓
Some magnetic field lines cross. ✓ (3)

4.1.3 (plotting) compass ✓ (1)



4.2 When charged particles from the sun ✓ reach the magnetic field of Earth (magnetosphere), ✓ the particles follow the magnetic field lines ✓ to the north pole. When they collide with particles in the atmosphere of Earth, light is given out. ✓ (4)

[12]

QUESTION 5

5.1 The net charge of a isolated system remains constant during any physical process ✓✓ (2)

$$5.2.1 \ Q_{xy} = \frac{Q_x + Q_y}{2} \\ = \frac{+20 + (-8)}{2} \checkmark \\ = +6 \mu\text{C} \checkmark \\ Q_y = +6 \mu\text{C} \checkmark$$

$$Q_{xz} = \frac{Q_x + Q_z}{2} \\ = \frac{+6 + 0}{2} \checkmark \\ = +3 \mu\text{C} \checkmark \\ Q_x = +3 \mu\text{C} \checkmark \\ Q_z = +3 \mu\text{C} \checkmark \quad (5)$$

$$5.2.2 \ \text{number of electrons} = \frac{\text{new } Q - \text{old } Q}{-1,6 \times 10^{-19} \text{ C}} \checkmark \\ = \frac{+6 \mu\text{C} - 20 \mu\text{C}}{-1,6 \times 10^{-19} \text{ C}} \checkmark \\ = 8,75 \times 10^{13} \text{ electrons} \checkmark \quad (3)$$

5.2.3 When X touches Y they share charges
Each becomes identically charged ✓
Like charges repel. ✓ (2)

5.2.4 No. ✓
- The new sum of charges is not equal to the original sum. ✓
Law of conservation of charge is not obeyed. ✓ (3)

5.2.5 Towards Z ✓
- Z is positively charged. It induces a negative ✓ charge on the sphere in the
area near Z. Unlike charges will attract each other. ✓ (3)

[18]

QUESTION 6

6.1 Emf is p.d. measured across a battery when no current is flowing ✓ while terminal
potential difference is p.d. measured across a battery when there is current
flowing. ✓ (2)

6.2 Increase temperature (2)
Increase length
Decrease surface area (any two) ✓ ✓ (2)

6.3.1 So that it can measure the potential drop across a load ✓ ✓
or
measure the energy needed to move a quantity of charge across a load. ✓ ✓ (2)
6.3.2 so that very little current passes through it. ✓ In this way it can measure voltage
drop across the load. ✓ (2)

6.4.1 $\frac{1}{R_T} = \frac{1}{R_1} + \frac{1}{R_2}$ ✓
 $= \frac{1}{6} + \frac{1}{3}$ ✓
 $R_T = 2\Omega$ ✓ (3)

6.4.2 $R_T = R_T + R_3$
 $= 2 + 5$ ✓
 $= 7\Omega$ ✓ (2)

6.4.3 $\frac{6V}{3} = 2V$ ✓ (1)

6.4.4 rate of flow of charge ✓ ✓ (2)

6.4.5 $Q = It$ ✓
 $= 0,86 \times 120$ ✓
 $= 103,2C$ ✓ (4)

Copyright reserved

Please turn over

6.4.6 $W = V.Q$ ✓
 $= 6 \cdot 103,2$ ✓
 $= 619,2J$ ✓ (3)

6.4.7 Decreases ✓
Resistance of the circuit will increase ✓ ✓ (3)

TOTAL MARKS: 100

Copyright reserved

Please turn over

C

C