



## Education and Sports Development

Department of Education and Sports Development  
Department van Onderwys en Sport Ontwikkeling  
Lefapha la Thuto le Tlhabololo ya Metshameko  
**NORTH WEST PROVINCE**

**GRADE 10**

**PHYSICAL SCIENCES**

**JUNE 2018**

**EXAMINATION**

**MARKS : 150**

**TIME: 2 HOURS**

This paper consists of 14 pages, including a Data sheet and a Periodic table.



NW/JUNE/PHY/ EMIS/6\*\*\*\*\*

**INSTRUCTIONS AND INFORMATION**

1. Write your name in the appropriate space on the ANSWER BOOK.
2. This paper consists of 13 questions. Answer ALL of them
3. Non-programmable pocket calculators may be used.
4. Appropriate mathematical instruments may be used..
5. Number the answers correctly according to the numbering system used in this question paper.
6. You are advised to use the attached DATA SHEETS. YOU MAY DETACH THEM.
7. Show ALL formulae and substitutions in ALL calculations.
8. Round off your final numerical answers to a minimum TWO decimal places where necessary.
9. Give brief motivations, discussions, et cetera where required.
10. Write neatly and legible.



**QUESTION 1 (MULTIPLECHOICE QUESTIONS)**

Four options are provided as possible answers to the following questions. Each question has only ONE correct answer. Write only the letter (**A-D**) next to the question number (1.1-1.10) in the ANSWER BOOK, for example 1.11 **C**.

- 1.1. Classify graphite as one of the following:  
A. element  
B. compound  
C. homogenous mixture  
D. heterogeneous mixture (2)
- 1.2. Which ONE of the following pair of atoms will most probable form an ionic bond:  
A. F and O  
B. N and O  
C. Na and O  
D. C and O (2)
- 1.3. The manner on which the electrons is placed around the nucleus of the atom is called .....
- A. electronegativity  
B. electron configurations  
C. electron affinity  
D. ionization energy (2)
- 1.4. Which ONE of the following statements is true for GROUP I (ONE) on the periodic table? As you move from top to bottom in the group, the.....  
A. atomic radius increase  
B. ionization energy increase  
C. amount of valence electrons increase  
D. the electron affinity increase. (2)
- 1.5. Which ONE of the following describes the particles in a liquid the best?  
A. Fixed shape and fixed volume  
B. Fixed shape and changeable volume  
C. Fixed volume and changeable shape.  
D. Changeable shape and changeable volume (2)
- 1.6. Iodine can go directly from a solid to a gas phase. This process is called ....  
A. melting  
B. evaporation  
C. decomposition  
D. sublimation (2)



- 1.7. The directions of magnetic field lines on the outside of a magnet is from .....
- A. south pole to north pole
  - B. north pole to south pole
  - C. positive pole to the negative pole
  - D. negative pole to the positive pole
- (2)
- 1.8. A string on a violin is plucked lightly and it vibrates. The sound waves that it produces are.....
- A. transverse waves and need a medium to propagate.
  - B. transverse waves and do not need a medium to propagate.
  - C. longitudinal waves and need a medium to propagate.
  - D. longitudinal waves and do not need a medium to propagate.
- (2)
- 1.9. The high energy electromagnetic waves that are used to destroy cancer cells because it has a high penetration ability , is....
- A. X-rays
  - B. Gamma rays
  - C. Ultraviolet rays
  - D. Ultra sound
- (2)
- 1.10. Study the following circuit diagram. Resistors  $r_1$  and  $r_2$  have the same resistance.

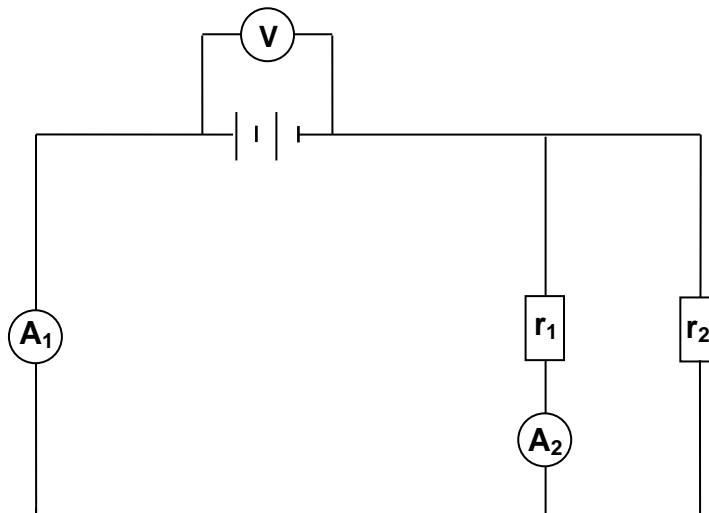

How does the reading on ammeter  $A_2$  compare to that of  $A_1$ ?

- A.  $A_2 = A_1$
  - B.  $A_2 = 2A_1$
  - C.  $A_2 = \frac{1}{2}A_1$
  - D.  $A_2 = \frac{1}{4}A_1$
- (2)

[20]



**QUESTION 2**

- 2.1. What is the difference between an element and a compound? (2)
- 2.2. Classify the following substances as one of the following: element, compound, homogenous mixture, or heterogeneous mixture.
- 2.2.1. smoke (1)
  - 2.2.2. table salt (1)
  - 2.2.3. oxygen gas (1)
  - 2.2.4. wine (1)
- 2.3. Define the term heterogeneous mixture. (2)
- 2.4. Metals and non-metals have specific properties that makes it possible to use them for specific uses. Name the properties that is applicable in the following examples and uses:
- 2.4.1. metals are used for electrical wiring. (1)
  - 2.4.2. metals are used for steel frames in huge buildings. (1)
  - 2.4.3. metals are used for wiring of fences. (1)

**[11]****QUESTION 3**

- 3.1. Write down the chemical formula for the following compounds:
- 3.1.1. Lithium bromide (1)
  - 3.1.2. Magnesium hydroxide (1)
  - 3.1.3. Iron (III) carbonate (1)
- 3.2. Give the name of the following compounds:
- 3.2.1.  $\text{NaNO}_2$  (1)
  - 3.2.2.  $\text{SO}_3$  (1)
  - 3.2.3.  $\text{Cu}_2\text{SO}_4$  (1)

**[6]**

**QUESTION 4**

The cooling curve for chlorine gas is given below:

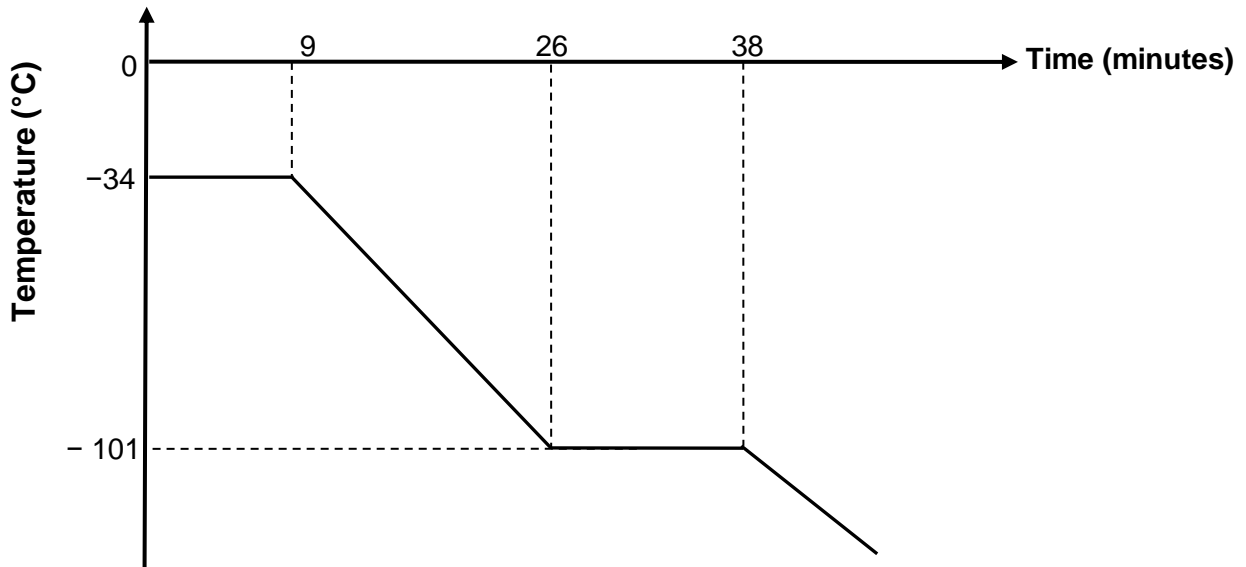

- 4.1. At which phase is chlorine at 38 minutes? (1)
- 4.2. What is the melting point of chlorine? (1)
- 4.3. Which phase change occurs between 0 and 9 minutes? (1)
- 4.4. Which phase change occurs between 26 and 38 minutes? (1)
- 4.5. Explain why the temperature remains constant between 26 and 38 minutes. (2)
- 4.6. Energy is released as chlorine changes phase. Explain how the following properties change as chlorine changes phase between 26 and 38 minutes
- 4.6.1. Spaces between the particles. (1)
- 4.6.2. Movement of the particles. (1)
- 4.6.3. Strength of the bonds between the particles. (1)
- 4.7. Define the term boiling point. (2)
- 4.8. What kind of change takes place as chlorine cools down? Physical or chemical? Give a reason for your answer. (2)

**[13]**

**QUESTION 5**

- 5.1. Complete the following table. Do not redraw the table. Write the number (5.1.1 – 5.1.5) down and write the correct answer next to the number:

Chemical symbol	Number of protons	Number of electrons	Number of neutrons
Hg	5.1.1	5.1.2	5.1.3
P <sup>3-</sup>	15	5.1.4	16
Mg <sup>2+</sup>	12	5.1.5	12

(5)

- 5.2. Draw an Energy diagram (Aufbau-diagram/ Orbital box-diagram) for:

5.2.1. S (2)

5.2.2. Mg<sup>2+</sup> (2)

- 5.3 Study the electron configuration of the following unknown substances:

**A:**  $1s^2 2s^2 2p^6 3s^2 3p^1$

**B<sup>-</sup>:**  $1s^2 2s^2 2p^6$

5.3.1 Identify substance **A** and **B<sup>-</sup>**. (2)

5.3.2. How many valence electrons does **A** have? (1)

5.3.3. What is the valency of **B<sup>-</sup>**? (1)

- 5.4. Lithium is found in nature as two stable isotopes: Li-6 and Li-7.

Li-7 is more abundant than Li-6. A sample of Lithium will consist of 92,5% of Li-7 and the rest of Li-6.

5.4.1. Explain the term isotope. (2)

5.4.2. Calculate the relative atomic mass of Lithium. (3)

- 5.5. Calcium has a first ionisation energy of 590 kJ.mol<sup>-1</sup>, a second ionization energy of 1145 kJ.mol<sup>-1</sup> and a third ionization energy of 4910 kJ.mol<sup>-1</sup>. Explain why the third ionization energy is so much more than the first two. (3)

**[21]****QUESTION 6**

- 6.1. Which kind of bond exists between atoms of the following substances? (choose from: covalent bond, ionic bond or metal bond):

6.1.1 AlF<sub>3</sub> (1)

6.1.2. N<sub>2</sub> (1)

6.1.3. Na (1)

6.1.4. BCl<sub>3</sub> (1)

- 6.2. Use Lewis diagrams to indicate how AlF<sub>3</sub> is formed. (3)

**[7]**

**QUESTION 7**

Lithium is ignited to react with oxygen gas in the air to form lithium oxide

- 7.1. Is this a chemical or a physical change? Give a reason for your answer. (2)
- 7.2. Write a balanced equation for this reaction. (3)
- 7.3. Prove that the law of conservation of mass is adhered to in this reaction. (3)

**[8]****QUESTION 8**

The diagram below shows a wave pattern of a transverse wave. It takes the wave 0,15 seconds to transfer energy from point **A** to point **C**.

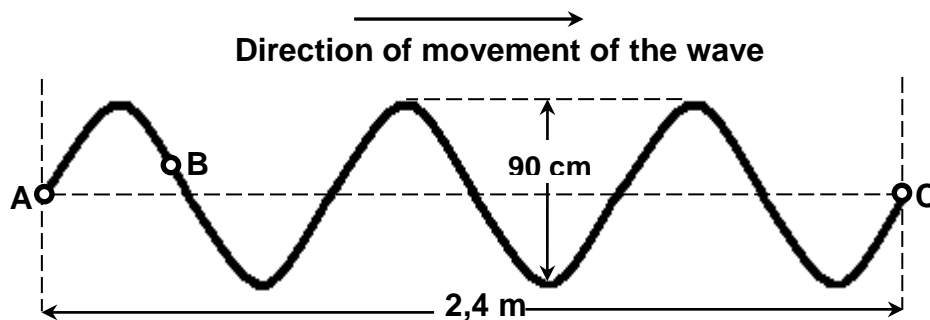

- 8.1. Give the definition of frequency. (2)
- 8.2. Give the amplitude of this wave in meters? (2)
- 8.3. What is the wavelength of this wave? (2)
- 8.4. In which direction is **B** moving? UP or down? (1)
- 8.5. What does it mean when we say that two points are in phase? (1)
- 8.6. Calculate the frequency of the wave. (4)
- 8.7. Calculate the speed of the wave. (3)

**[15]**

**QUESTION 9**

Bats have very bad eye sight and depend on echo location to find their way in the dark. Echo location is an example of sonar from ultra sound. The frequency of the sound produced by a bat is 100 kHz.

- 9.1. What is ultra sound? (1)
- 9.2. What type of wave is a sound wave? Transversal or Longitudinal? (1)
- 9.3. If the speed of sound in a cold cave is  $338 \text{ m}\cdot\text{s}^{-1}$ , and a bat in the cave makes a sound. The echo of this sound from an insect reaches the bat after 0,02 seconds. How far is the insect from the bat? (4)

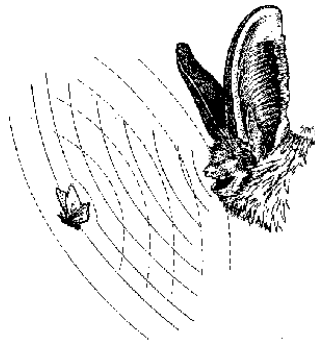

- 9.4. Name one example where humans use sonar. (1)

**[7]****QUESTION 10**

A certain radio station emits radio waves with a frequency of 94,4 MHz. ( $1 \text{ MHz} = 1 \times 10^6 \text{ Hz}$ ).

- 10.1. Of all the electromagnetic waves, does radio waves have the BIGGEST or the SMALLEST frequency? (1)
- 10.2. Calculate the wavelength of these waves. (3)
- 10.3. Calculate the energy of a photon of these waves. (3)
- 10.4. Explain in detail why radio stations use radio waves and not sound waves to transmit their music. (3)

**[10]**

**QUESTION 11**

The following magnetic field pattern is seen when the poles of two magnets are brought close together

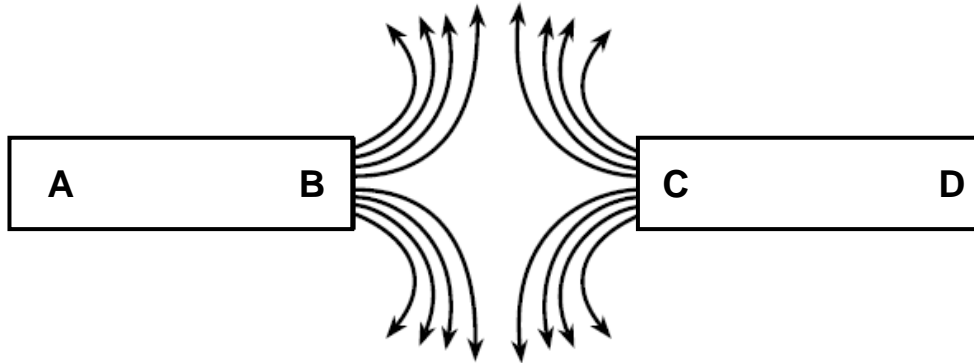

- 11.1 Is poles **B** and **C** THE SAME or DIFFERENT? Give a reason for your answer. (2)
- 11.2. What will pole **A** and pole **C** do to each other? Write only ATTRACKT or REPELL.(1)
- 11.3. If you hold a compass close to pole **D**, will the compass POINT TOWARDS D or AWAY FROM D? (1)
- 11.4. Explain the difference between the Earth's Geographical North and Magnetic North. (2)
- 11.5. How does the Earth's magnetic field protect us from solar wind? (2)

**[8]**

**QUESTION 12**

You have two identical isolated metal spheres. Sphere  $Q_1$  has a charge of  $-12 \times 10^{-6} \text{ C}$  and sphere  $Q_2$  has a charge of  $+6 \times 10^{-6} \text{ C}$ , as shown in the diagram below.

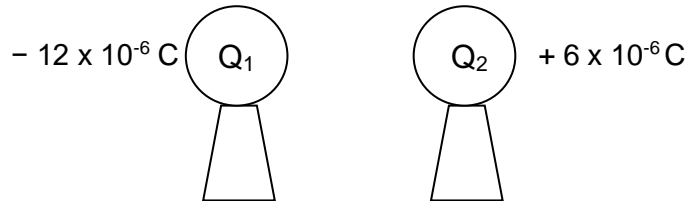

- 12.1. Calculate the amount of electrons on sphere  $Q_1$ . (3)
- 12.2. State the law of conservation of charge in words. (2)
- 12.3. Sphere  $Q_1$  is brought closer to  $Q_2$  until the two spheres touch each other.  $Q_1$  is then placed back in its original position. Calculate the charge on both spheres after they have touched each other. (3)
- 12.4. Will sphere  $Q_1$  and  $Q_2$  REPELL or ATTRACT each other after they have made contact? (1)
- 12.5. In which direction did the electrons flow when the two spheres were touching each other? Write only **FROM  $Q_1$  TO  $Q_2$**  or **FROM  $Q_2$  TO  $Q_1$** . (1)

**[10]**

**QUESTION 13**

Study the following circuit diagram. The battery has an unknown EMF. Resistor  $r_1$  has a resistance of  $8\ \Omega$ , resistor  $r_2$  has a resistance of  $12\ \Omega$ , and resistor  $r_3$  has a resistance of  $6\ \Omega$ . The ammeter **A** gives a reading of  $0,5\ \text{A}$ .

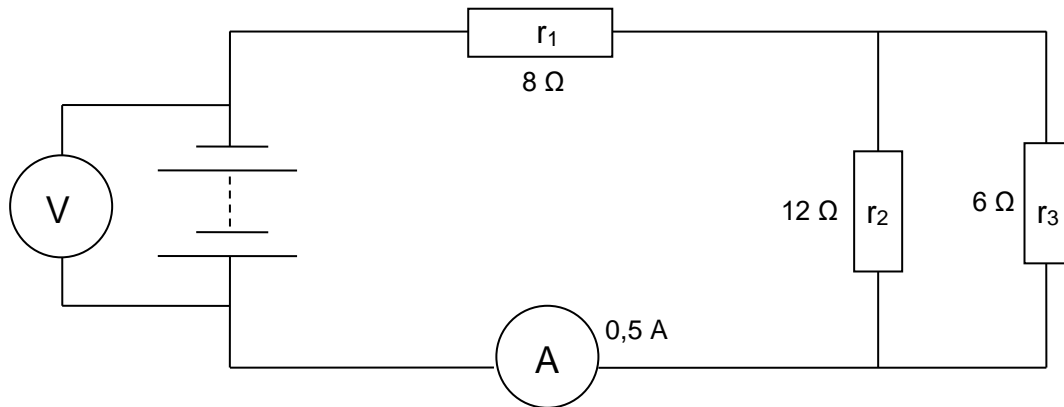

- 13.1. Calculate the total resistance of the circuit. (5)
- 13.2. Calculate the reading on voltmeter **V**. (3)
- 13.3. Calculate the amount of charge that flows through the ammeter in 5 minutes. (3)
- 13.4. How will the ammeter reading **A** be influenced if resistor  $r_3$  is removed from the circuit? Write down INCREASE, DECREASE or STAY THE SAME. (1)
- 13.5. Explain your answer to question 13.4 without using calculations. (2)

**[14]****GRAND TOTAL: 150 MARKS**

**DATA FOR PHYSICAL SCIENCES GRADE 10**  
**GEGEWENS VIR FISIESTE WETENSAPPE GRAAD 10**

**TABLE 1: PHYSICAL CONSTANTS/ TABEL 1: FISIESTE KONSTANTES**

<b>NAME/NAAM</b>	<b>SYMBOL/SIMBOOL</b>	<b>VALUE/WAARDE</b>
Acceleration due to gravity <i>Swaartekragversnelling</i>	g	9,8 m·s <sup>-2</sup>
Speed of light in a vacuum <i>Spoed van lig in 'n vakuum</i>	c	3,0 x 10 <sup>8</sup> m·s <sup>-1</sup>
Charge on electron <i>Lading op elektron</i>	e	-1,6 x 10 <sup>-19</sup> C
Electron mass <i>Elektronmassa</i>	m <sub>e</sub>	9,11 x 10 <sup>-31</sup> kg
Planck's constant <i>Planck se konstante</i>	h	6,63 x 10 <sup>-34</sup> J·s
Avogadro's constant <i>Avogadro se konstante</i>	N <sub>A</sub>	6,02 x 10 <sup>23</sup> mol <sup>-1</sup>

**TABLE 2: FORMULAE/ TABEL 2: FORMULES**

**WAVES, SOUND AND LIGHT/GOLWE, KLANK EN LIG**

$v = \lambda f$	$T = \frac{1}{f}$
$E = hf$	$E = \frac{hc}{\lambda}$

**ELECTROSTATICS/ ELEKTROSTATIKA**

$n = \frac{Q}{q_{e^-}}$ or/of $n = \frac{Q}{e}$	$Q = \frac{Q_1 + Q_2}{2}$
---	---------------------------

**ELECTRIC CIRCUITS/ ELEKTRIESE STROOMBANE**

$R = \frac{V}{I}$	$q = I\Delta t$
$W = Vq$	$P = \frac{W}{\Delta t}$
$R_s = R_1 + R_2 + \dots$	$\frac{1}{R_p} = \frac{1}{R_1} + \frac{1}{R_2} + \dots$



