



Education and Sports Development

Department of Education and Sports Development
Department van Onderwys en Sport Ontwikkeling
Lefapha la Thuto le Tlhabololo ya Metshameko
NORTH WEST PROVINCE

GRADE 10

PHYSICAL SCIENCES

JUNE 2019

EXAMINATION

MARKS : 150

TIME: 2 HOURS

This paper consists of 14 pages, which includes a Data sheet and a Periodic table.

INSTRUCTIONS AND INFORMATION

1. Write your name in the appropriate space on the ANSWER BOOK.
2. This paper consists of 13 questions. Answer ALL of them
3. Non-programmable pocket calculators may be used.
4. Appropriate mathematical instruments may be used
5. Number the answers correctly according to the numbering system used in this question paper.
6. You are advised to use the attached DATA SHEETS. YOU MAY DETACH PAGE 13 AND 14.
7. Show ALL formulae and substitutions in ALL calculations.
8. Round off your final numerical answers to a **minimum TWO decimal places** where necessary.
9. Give brief motivations, discussions, et cetera where required.
10. Write neatly and legible.



QUESTION 1 (MULTIPLECHOICE QUESTIONS)

Four options are provided as possible answers to the following questions. Each question has only ONE correct answer. Write only the letter (A - D) next to the question number (1.1 - 1.10) in the ANSWER BOOK, for example 1.11. C.

- 1.1. Elements in the same period will have the same amount of ...
- A. electrons
 - B. protons
 - C. valence electrons
 - D. core electrons
- (2)
- 1.2. Consider the isotope $^{17}_8\text{X}$. The nucleus of this atom contains:
- A. 8 neutrons and 9 protons
 - B. 9 neutrons and 8 protons
 - C. 17 neutrons and 8 protons
 - D. 8 neutrons and 17 protons
- (2)
- 1.3. The type of particle(s) out of which a diamond consists is:
- A. loose atoms
 - B. covalent molecular structure
 - C. covalent network structure
 - D. ionic lattice
- (2)
- 1.4. Which ONE of the following is not a property of metals?
- A. shiny
 - B. conductors of heat
 - C. malleable and ductile
 - D. insulators of electricity
- (2)
- 1.5. Sound cannot travel through the following:
- A. steel
 - B. a vacuum
 - C. water
 - D. wood
- (2)

- 1.6. If the period (T) of a transverse wave were doubled, what effect would this have on the frequency (f) of the transverse wave? In terms of f it will be
- A. f
 - B. 2f
 - C. $\frac{1}{2}f$
 - D. 4f
- (2)
- 1.7. An object that is positively charged has...
- A. lost protons
 - B. recieved protons
 - C. lost electons
 - D. recieved electons
- (2)
- 1.8. An increase in amplitude and decrease in frequency of a sound wave, will...
- A. increase in loudness and decrease in pitch
 - B. decrease in loudness and increase in pitch
 - C. increase in loudness and in pitch
 - D. decrease in loudness and in pitch
- (2)
- 1.9. Which ONE of the following arragements shows a decrease in frequency (from large to small) for the different types of electromagnetic radiation?
- A. gamma rays, visible light, radio waves
 - B. infrared rays, ultraviolet light, X-rays
 - C. radio waves, infrared rays, visible light,
 - D. visible light, X-rays, gamma rays
- (2)
- 1.10. The rate at which 1 C of charge flows in a circuit is a measurement of:
- A. resistance
 - B. current
 - C. potential difference
 - D. power
- (2)

[20]

QUESTION 2

Boron has 2 natural occurring isotopes namely B -10 and B -11.

- 2.1. Give the definition of *isotopes*. (2)
- 2.2. How many protons does boron-10 have? (1)
- 2.3. How many neutrons does boron-11 have? (1)
- 2.4. Boron has a relative atomic mass of 10,801. Calculate the percentage occurrence of each of the two isotopes of boron. (4)

[8]**QUESTION 3**

Chlorine is a highly poisonous, greenish yellow gas with a strong, sharp choking odour. It was one of the first poisonous gasses used in 1915 in World War I. The chlorine gas reacts with water in your airways to form the strong acid, hydrochloric acid, in the following reaction:

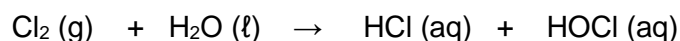

- 3.1. Is the reaction between chlorine and water a physical or chemical change? (1)
- 3.2. Give a reason for your answer in question 3.1. (1)
- 3.3. Draw a Lewis diagram for a **Cl₂** molecule. (2)
- 3.4. Name the group on the Periodic table to which the chlorine atom belongs. (1)
- 3.5. Write a balanced chemical reaction for when chlorine reacts with sodium to form table salt (NaCl). (3)
- 3.6. Name the type of chemical bond (covalent, ionic or metallic bond) that exists in:
- 3.6.1. HCl (1)
- 3.6.2. Na (1)
- 3.6.3. NaCl. (1)
- 3.7. Give the electron configuration for a Cl atom. (2)
- 3.8. Draw an Aufbau-diagram (Orbital box-diagram) for a Na⁺ ion. (2)
- 3.9. How many electrons does a Cl⁻ ion have? (1)
- 3.10. How many valence electrons does a Na atom have? (1)

[17]

QUESTION 4

Rosemary teaches her little sister how to make a cup of coffee. She instructs her to boil some tap water in the kettle. Add 1 teaspoon of coffee and 2 teaspoons of sugar in the mug. Add the hot water to the mug and stir until dissolved and lastly add some milk.

- 4.1. Classify the following substances as one of the following:
element, compound, homogeneous mixture, or heterogeneous mixture.
- 4.1.1. milk (1)
4.1.2. sugar (1)
4.1.3. tap water (1)
4.1.4. sugar and coffee powder mixture (before adding the water) (1)
- 4.2. Define the term *homogeneous mixture*. (2)
- 4.3. Classify the following processes as physical or chemical change:
- 4.3.1. Boiling of water. (1)
4.3.2. Dissolving coffee, sugar and milk in hot water. (1)
- 4.4. Below are two different objects. For each one, state whether it would be best made from a metal or a non-metal. Then also state which property of that type of substance (metal/non-metal) makes it suitable for that purpose.
- 4.4.1. burglar bars (2)
4.4.2. oven gloves (2)

[12]**QUESTION 5**

Study the following chemical reactions:

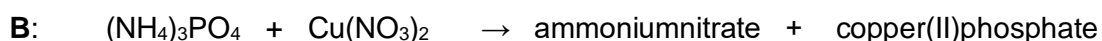

- 5.1. Give the chemical name for the following substances:
- 5.1.1. KOH (1)
5.1.2. K_2S (1)
5.1.3. $\text{Cu}(\text{NO}_3)_2$ (1)
- 5.2. Write down the chemical formula for the following compounds:
- 5.2.1. ammoniumnitrate (1)
5.2.2. copper(II)phosphate (1)
- 5.3. Balance the equation for chemical reaction **A**. (2)
- 5.4. Give the name of ONE of the laws that you have to follow when balancing equations. (1)

[8]

QUESTION 6

The table below gives the temperature for bromine every 2 minute as bromine (starting at solid phase) was heated:

Time (Min)	0	2	4	6	8	10	12	14	16	18	20	22	24	26	28	30	32
Temperature (°C)	-9	-7	-7	-7	-2	4	10	22	34	46	58	58	58	58	64	68	72

- 6.1. What is the boiling point of bromine? (1)
- 6.2. Define the term *boiling point*. (2)
- 6.3. At which phase is bromine at 10 minutes? (1)
- 6.4. Which phase change occurs between 20 and 26 minutes? (1)
- 6.5. Explain why the temperature remains constant between 2 and 6 minutes. (2)
- 6.6. Between what time frames are the following true for the particles of bromine?
- 6.6.1. There are very large spaces between the particles. (1)
- 6.6.2. The particles use the energy to completely break the intermolecular forces between them. (1)

[9]**QUESTION 7**

Below is a table showing the first 3 ionisation energies for some elements which occur in Group 1 and 2 of the Periodic Table.

Element	Group number	1st ionisation energy (kcal·mol⁻¹)	2nd ionisation energy (kcal·mol⁻¹)	3rd ionisation energy (kcal·mol⁻¹)
Li	1	124	1744	2813
Na	1	118	1091	1645
K	1	99	734	1052
Be	2	215	420	3548
Mg	2	176	347	1848
Ca	2	141	274	1181

- 7.1. Define the term *ionisation energy*. (2)
- 7.2. Explain the decreasing trend for the first ionisation energies of the Group 1 elements?. (2)
- 7.3. The second ionisation energies of the Group 1 elements are much higher compared to the second ionisation energies of the Group 2 elements? Explain this difference. (2)

[6]

QUESTION 8

Two transverse pulses, **X** and **Y**, are moving at the same time at the same speed along a light string. Pulse **X** is moving to the right with an amplitude of **+5 cm**, while pulse **Y** is moving to the left with an amplitude of **-8 cm**. Pulses **X** and **Y** meet at position **Z**. Assume that all energy is conserved.

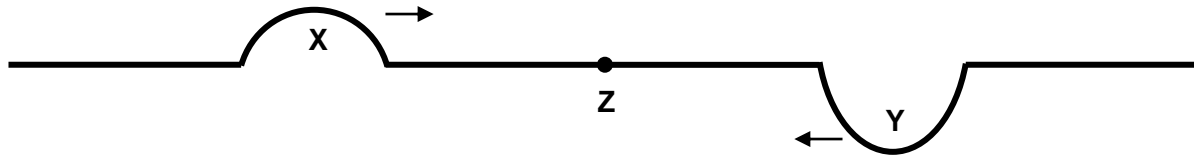

- 8.1 Make a labelled sketch to represent these two pulses when they meet at point **Z**. Show the amplitude on your sketch. (2)
- 8.2. What type of interference will take place when these two pulses meet? (1)
- 8.3. How will the amplitude of pulse **X** change after the interference with pulse **Y** at point **Z**? Write only INCREASE, DECREASE or STAY THE SAME. (1)

The distance between 9 consecutive wave crests of a transverse wave is 16 cm. The wave travels at a speed of the 0,5 m·s⁻¹.

- 8.4. Give the definition of *transverse wave*. (2)
- 8.5. Calculate the wavelength of the wave in meters. (2)
- 8.6. Calculate the frequency of the wave. (3)
- 8.7. Calculate the period of the wave. (3)

[14]

QUESTION 9

The timekeepers at an athletics meeting are some distance away from the starter. They start their stopwatches when they hear the shot of the starter’s pistol rather than when they see the smoke emerging from the starter’s pistol

- 9.1. What kind of waves are the sound waves the timekeepers hear? (1)
 - 9.2. Does the error the timekeepers make work to the runners’ advantage or disadvantage? Give a reason for your answer. (2)
 - 9.3. If the timekeepers are a distance of 128 m away from where the starter’s pistol is being shot, calculate the time that it will take for the sound to reach their ears. (3)
- The speed of sound in air is 340 m·s⁻¹

[6]



QUESTION 10

When doctors need to determine the seriousness of a fracture, they take a photo of the broken bones. One such a photo is shown below.



- 10.1. What kind of electromagnetic waves are used to take such photos? (1)
- 10.2. The frequency of such an electromagnetic wave is $5,8 \times 10^{22}$ Hz. Calculate the energy of a photon of this electromagnetic wave. (3)
- 10.3. Give the definition of a *frequency*. (2)

The amount of cell phone users have drastically increased in the last decade. Research claims that the radiation emitted by cellphones can affect living cells. There is a close link between the amount of cellphone radiation a person is exposed to and the increased risk of braintumors, eyecancer, birth defects, hearingloss and loss of balance.

- 10.4. What kind of electromagnetic waves is used for cell phone signals? (1)
- 10.5. Provide TWO precautions you can take to decrease the amount of cell phone radiation you are exposed to? (2)

[9]



QUESTION 11

Carla and Karen find a piece of nickel and decide to magnetise it. They move it back and forth over a permanent magnet for some time.

In order to check whether or not the piece of nickel has been magnetised, they cover it with a plastic sheet and sprinkle iron filings on to it. The iron filings arrange themselves in a pattern which is similar in shape as that of a bar magnet.

- 11.1. What is a magnetic field? (2)
- 11.2. Draw a neat sketch that shows the magnetic field lines around a bar magnet. (3)
- 11.3. How would Carla and Karen determine the direction of the field at any point? (1)
- 11.4. Explain briefly, in terms of domain theory, what happened when the piece of nickel was being magnetised. (3)
- 11.5. What will Carla and Karen notice when the following poles of two magnets are brought close together?
- 11.5.1. a north pole and a south pole (1)
- 11.5.2. a north pole and a north pole (1)

[11]

QUESTION 12

You have two identical isolated metal spheres that is hanging on silk threads. Sphere Q_1 has a **excess of $3,75 \times 10^{13}$ electrons** and sphere Q_2 has an unknown charge, as shown in the diagram below.

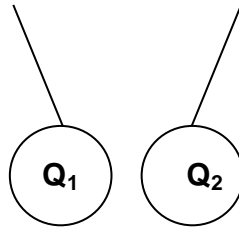

- 12.1. Calculate the amount of charge on sphere Q_1 . (3)
- 12.2. What kind of charge (positive or negative) does sphere Q_2 have? Explain your answer. (2)

When the two spheres are allowed to move, they swing to towards each and touch each other. They then immediately swing apart and stay like shown in the diagram below.

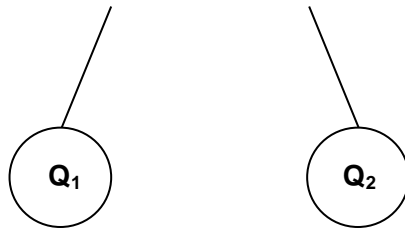

- 12.3. State the principle of conservation of charge in words. (2)
- 12.4. Explain why the two spheres swing apart after touching. (2)
- 12.5. The charge on both spheres after touching is $+ 2 \times 10^{-6} \text{ C}$. Calculate the charge on sphere Q_2 before the two spheres touched. (3)
- 12.6. In which direction did the electrons flow when the two spheres were touching each other? Write only **FROM Q_1 TO Q_2** or **FROM Q_2 TO Q_1** . (1)

[13]

QUESTION 13

Study the circuit diagram below. The three resistors are identical, each has a resistance of $6\ \Omega$. Voltmeter V_1 has a reading of $12\ V$.

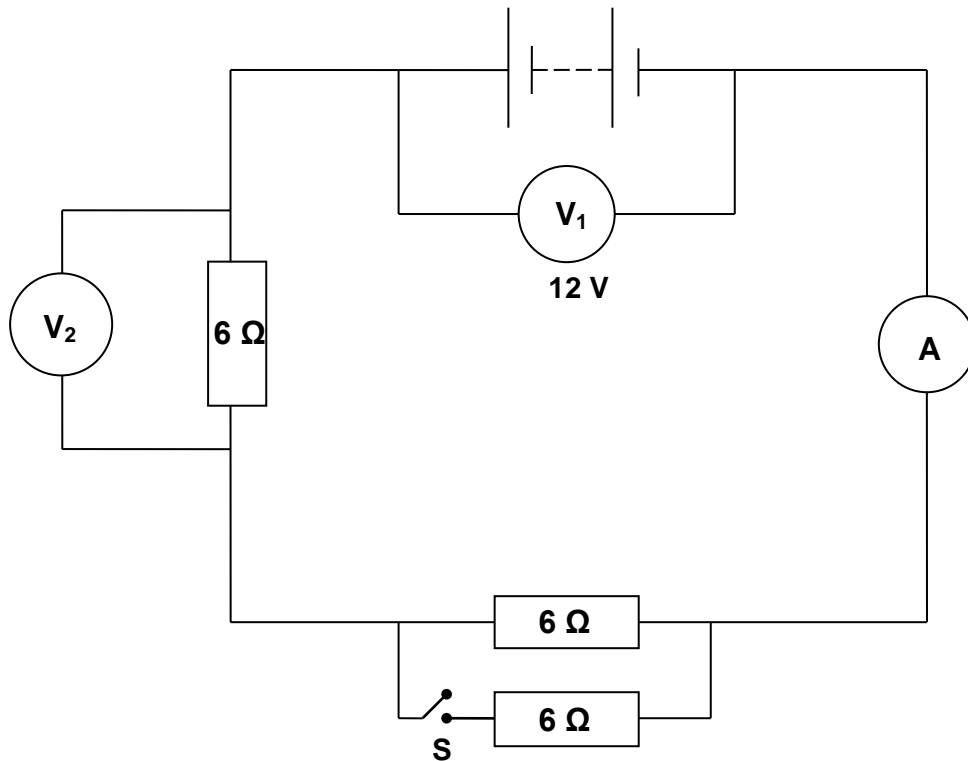

Switches S are initially OPEN.

- 13.1. Calculate the reading on the ammeter. (2)
- 13.2. Calculate the reading on the ammeter. (3)
- 13.3. Calculate the reading on voltmeter V_2 . (3)
- 13.4. Calculate the amount of charge that will pass through the ammeter in a time of 3 minutes. (3)

Switch S is now closed.

- 13.5. Calculate the resistance of the two resistors in parallel. (3)
- 13.6. How did the reading on the ammeter change when the switch was closed? Write down INCREASE, DECREASE or REMAINS THE SAME. (1)
- 13.7. Explain your answer to question 13.6 without using calculations. (2)

[17]

GRAND TOTAL: 150 MARKS



DATA FOR PHYSICAL SCIENCES GRADE 10
GEGEWENS VIR FISIESTE WETENSAPPE GRAAD 10

TABLE 1: PHYSICAL CONSTANTS/ TABEL 1: FISIESTE KONSTANTES

NAME/NAAM	SYMBOL/SIMBOOL	VALUE/WAARDE
Acceleration due to gravity <i>Swaartekragversnelling</i>	g	9,8 m·s ⁻²
Speed of light in a vacuum <i>Spoeed van lig in 'n vakuum</i>	c	3,0 x 10 ⁸ m·s ⁻¹
Charge on electron <i>Lading op elektron</i>	e	-1,6 x 10 ⁻¹⁹ C
Electron mass <i>Elektronmassa</i>	m _e	9,11 x 10 ⁻³¹ kg
Planck's constant <i>Planck se konstante</i>	h	6,63 x 10 ⁻³⁴ J·s
Avogadro's constant <i>Avogadro se konstante</i>	N _A	6,02 x 10 ²³ mol ⁻¹

TABLE 2: FORMULAE/ TABEL 2: FORMULES

WAVES, SOUND AND LIGHT/GOLWE, KLANK EN LIG

$v = \lambda f$	$T = \frac{1}{f}$
$E = hf$	$E = \frac{he}{\lambda}$

ELECTROSTATICS/ ELEKTROSTATIKA

$n = \frac{Q}{q_e}$ or/of $n = \frac{Q}{e}$	$Q = \frac{Q_1 + Q_2}{2}$
---------------------------------------------	---------------------------

ELECTRIC CIRCUITS/ ELEKTRIESE STROOMBANE

$R = \frac{V}{I}$	$q = I\Delta t$
$W = Vq$	$P = \frac{W}{\Delta t}$
$R_s = R_1 + R_2 + \dots$	$\frac{1}{R_p} = \frac{1}{R_1} + \frac{1}{R_2} \dots$



