

**GAUTENG DEPARTMENT OF EDUCATION
PROVINCIAL EXAMINATION
JUNE 2018
GRADE 10**

PHYSICAL SCIENCES

PAPER 1

TIME: 1½ hours

MARKS: 100

12 pages + 1 data sheet

**GAUTENG DEPARTMENT OF EDUCATION
PROVINCIAL EXAMINATION**

**PHYSICAL SCIENCES GRADE 10
(Paper 1)**

TIME: 1½ hours

MARKS: 100

INSTRUCTIONS AND INFORMATION

1. Write your name in the appropriate space on the ANSWER BOOK.
2. This question paper consists of **7** questions. Answer ALL the questions.
3. Do not spend too much time on one question
4. You may use a non-programmable calculator.
5. You may use appropriate mathematical instruments.
6. You are advised to use the attached DATA SHEETS.
7. Number the answers correctly according to the numbering system used in this question paper.
8. Write neatly and legibly.
9. Start EACH question on a NEW page in the ANSWER BOOK.
10. Leave ONE line between two sub-questions, for example between Question 2.1 and Question 2.2.
11. Show ALL formulae and substitutions in ALL calculations.
12. Round off your FINAL numerical answers to a minimum of TWO decimal places where needed.
13. Give brief motivations, discussions, et cetera where required.

SECTION A

QUESTION 1: MULTIPLE-CHOICE QUESTIONS

Four options are provided as possible answers to the following questions. Each question has only ONE correct answer. Write only the letter (A – D) next to the question number (1.1 – 1.10) on the answer book. Each answer counts TWO MARKS.

1.1 Which one of the following is a source of electromagnetic waves?

- A Magnets
- B Transverse waves
- C Longitudinal waves
- D Accelerating charges

(2)

1.2 Which one of the following is equal to 1 Volt?

- A $1 \text{ J}\cdot\text{C}^{-1}$
- B $1 \text{ C}\cdot\text{s}^{-1}$
- C 1 s^{-1}
- D 1 Hz

(2)

1.3 The distance between two consecutive crests in a wave train is 8 cm. If two complete waves pass a point in 1 s, then the velocity of the wave would be ...

- A $16 \text{ cm}\cdot\text{s}^{-1}$
- B $8 \text{ cm}\cdot\text{s}^{-1}$
- C $4 \text{ cm}\cdot\text{s}^{-1}$
- D $1,25 \text{ cm}\cdot\text{s}^{-1}$

(2)

1.4 Study the following sketch showing two charged spheres that are brought into contact and separated.

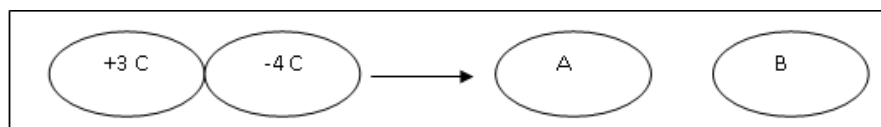

The following is correct for A and B after they touched each other:

- A 3 C and -4 C
- B -0,5 C each
- C Both neutral
- D -1 C each

(2)

- 1.5 Consider the diagram of a wave with a frequency of 5 Hz.

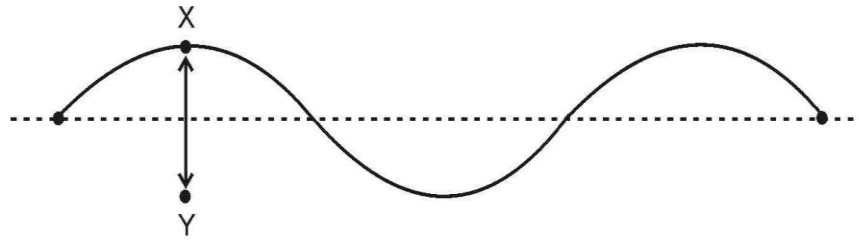

The distance XY can be described as ...

- A the wavelength.
 B the amplitude.
 C the period.
 D twice the amplitude. (2)
- 1.6 Which one of the following electromagnetic waves has the GREATEST penetrating ability?
 A Microwaves
 B Ultraviolet rays
 C Gamma rays
 D X-rays (2)
- 1.7 Ferromagnetic materials have many useful applications in everyday life. Which one of the following is correct in representing ferromagnetic materials?
 A Cobalt, carbon and nickel
 B Iron, nickel and sulphur
 C Cobalt, iron and nickel
 D Iron, copper and cobalt (2)

- 1.8 Consider the following diagram of a circuit. The light bulbs are not necessarily identical.

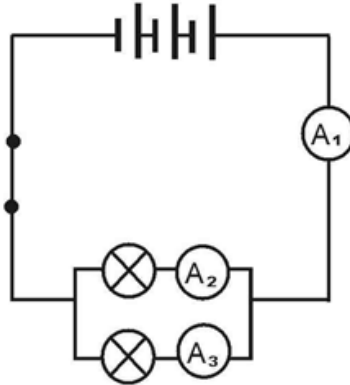

The reading on A_2 will be equal to ...

- A the reading on A_1 .
- B half the reading on A_1
- C the reading on A_3 minus the reading on A_1 .
- D the reading on A_1 minus the reading on A_3 . (2)

- 1.9 10 C of charge passes a point in a circuit in 2 minutes. The current in the circuit is ...

- A 0,083 A.
- B 0,2 A.
- C 5 A.
- D 12 A. (2)

- 1.10 Consider the following statements regarding voltmeters:

- (i) The reading of voltmeters connected across resistors is inversely proportional to the resistance of the resistor.
- (ii) When a switch in a circuit is closed, a voltmeter connected across a battery reads the emf of the battery.
- (iii) Voltmeters connected across equal resistors which are in parallel, will give the same reading.
- (iv) Voltmeters are always connected in parallel. (2)

Which of the above statements is true?

- A (i), (ii) and (iii)
- B (ii), (iii) and (iv)
- C (ii) and (iv)
- D All of the above

TOTAL SECTION A [20]

P.T.O.

SECTION B

QUESTION 2 (Start on a new page)

2.1 The distance between 13 consecutive wave crests in a ripple tank is 1,8 m. The waves travel through the water at a speed of $0,225 \text{ m}\cdot\text{s}^{-1}$.

2.1.1 Define the term *wavelength* of a wave. (2)

2.2 Calculate the ...

2.2.1 wavelength of the wave, in meters. (3)

2.2.2 frequency of the wave. (3)

2.3 The graph below shows the displacement of a leaf on a dam at intervals of 0,2 s after a disturbance has moved through the water at $12 \text{ m}\cdot\text{s}^{-1}$.

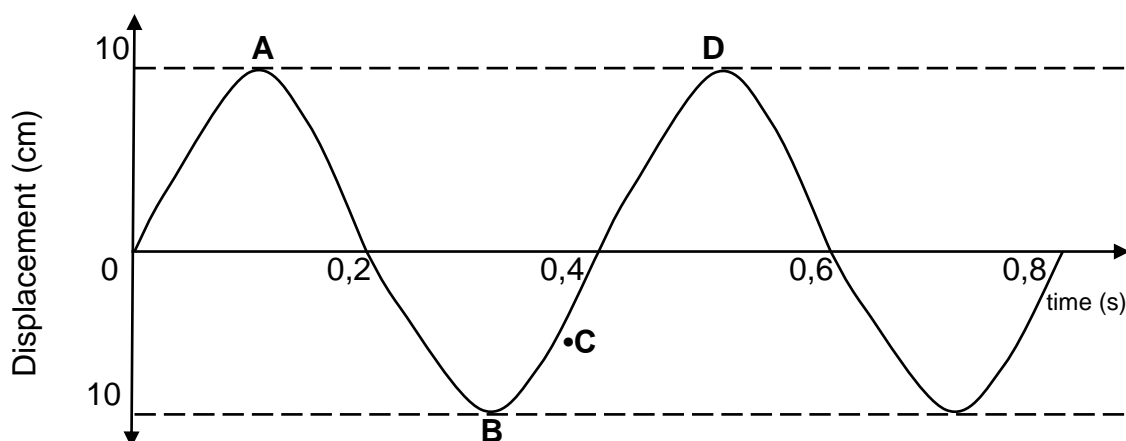

2.3.1 At position C, is the leaf moving upwards or downwards? (1)

2.3.2 Consider the points A,B, C and D in the diagram. Identify TWO points which are in phase. (1)

2.4 Calculate ...

2.4.1 the frequency of the wave. (2)

2.4.2 wavelength produced. (3)

2.5 What is meant by the term *amplitude* of a wave? (2)

2.6 The amplitude of the wave is now doubled. What is the value, in metres, of the new amplitude of the wave? (2)

[19]

QUESTION 3 (Start on a new page)

The diagram below shows two pulses, P and Q, that move towards each other in a slinky coil. Pulse P has an amplitude of 12 cm, and pulse Q has an amplitude of 8 cm. The pulses meet at position Y. Assume there is no loss of energy.

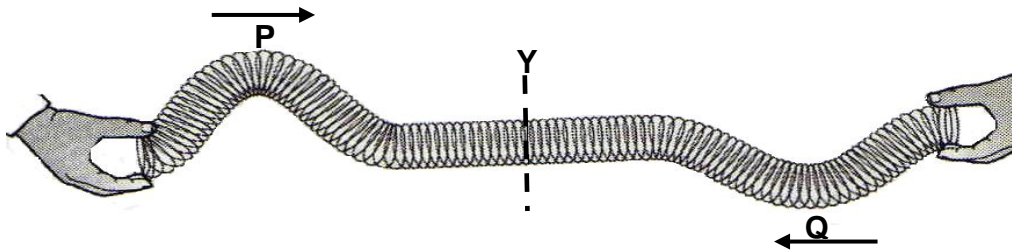

- 3.1 Define the term *transverse pulse*. (2)
- 3.2 Write down the name of the phenomenon that occurs when the two pulses meet at position Y. (1)
- 3.3 Calculate the amplitude of the resulting pulse when pulses P and Q meet at position Y. (2)
- 3.4 Pulse P travels a distance of 0,6 m in 1,5 s. Calculate the speed of pulse P. (3)
- 3.5 A tuning fork, with a frequency of 100 Hz, created a sound wave as illustrated in the sketch below.

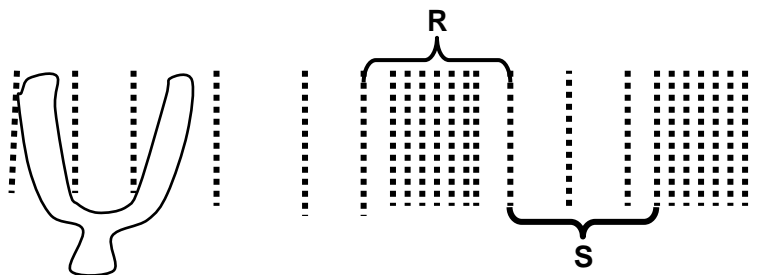

- 3.5.1 What type of wave does the tuning fork create? (1)
- 3.5.2 Name the parts labelled **R** and **S**. (2)
- 3.5.3 Calculate the period of the sound wave produced by the fork. (3)

- 3.6 During a thunderstorm, it is noted that the flash of lightning is seen before the loud roar of thunder is heard.

Provide a scientific explanation for this observation.

[<https://www.google.co.za/search?q=lightning+and+the+thunder&safe>]

(2)
[16]

QUESTION 4 (Start on a new page)

Learners investigate magnetism using a bar magnet. They place a sheet of paper over the magnet and sprinkle iron filings on the sheet of paper and observe the resulting pattern. They then place a compass in different positions around the bar magnet and observe the compass needle's direction.

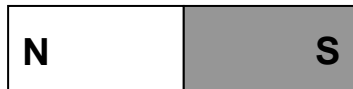

- 4.1 Briefly explain why the compass needle points are all pointing in the same direction when not close to a magnet. (2)
- 4.2 Sketch the magnetic field pattern around the bar magnet. (3)
- 4.3 During the investigation the bar magnet falls and breaks into six pieces. One of the learners suggests that they can now work individually by using iron filings to obtain the magnetic field patterns around the pieces of the bar magnet.

Will the magnetic field patterns obtained for each of the six pieces be the same as that obtained for the original bar magnet? Write down YES or NO.

(1)
[6]

QUESTION 5 (Start on a new page)

Two small, metal spheres, B and C, on insulated stands, carry charges of $+2 \times 10^{-9} \text{ C}$ and $-6 \times 10^{-9} \text{ C}$ respectively.

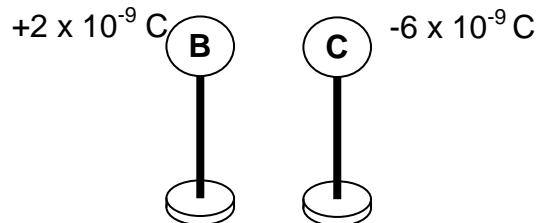

- 5.1 How does the number of electrons on sphere B compare with the number of protons on sphere B? Choose your answer from one of the following: LESS THAN, THE SAME AS or MORE THAN.

Give a reason for your answer.

(2)

- 5.2 The spheres are allowed to touch, after which they are separated again and returned to their original positions.

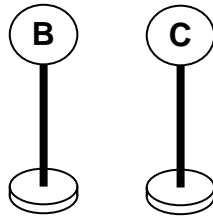

- 5.2.1 State the principle of **conservation of charge**.

(2)

- 5.2.2 In which direction are the electrons flowing while spheres B and C are in contact? Write down only from **B** to **C** or from **C** to **B**.

(1)

- 5.2.3 Briefly explain your answer to Question 5.2.2.

(2)

- 5.2.4 Calculate the charge on each sphere after they are separated.

(3)

- 5.2.5 Calculate the number of electrons transferred between the two spheres.

(3)

[13]

QUESTION 6 (Start on a new page)

- 6.1 The Wi-Fi (Wireless Fidelity) has fast become a very necessary tool for electronic communication, learning and accessing social platforms. Electromagnetic waves are essential in wireless communication. Wi-Fi makes use of low-frequency electromagnetic waves.



- 6.1.1 Name the type of electromagnetic waves used in Wi-Fi. (1)
- 6.1.2 State ONE advantage that the type of radiation named in 6.1.1 has for the use in Wi-Fi. (1)
- 6.2 A photon associated with a certain electromagnetic wave has $1,46 \times 10^{-24}$ J of energy.
- 6.2.1 Define the term **photon**. (2)
- 6.2.2 What is the speed at which this electromagnetic wave travels? (2)
- 6.2.3 Calculate the wavelength of this electromagnetic wave, in metres. (3)
- 6.3 If the wavelength of this electromagnetic wave was doubled, what effect would this have on its penetrating ability?
Write only INCREASE, DECREASE or REMAIN THE SAME. (2)
- 6.4 Briefly explain your answer to Question 6.3. (2)
- [13]**

QUESTION 7 (Start on a new page)

Consider the circuit below: The bulbs are identical. The resistance of the battery, ammeter and connecting wires can be ignored.

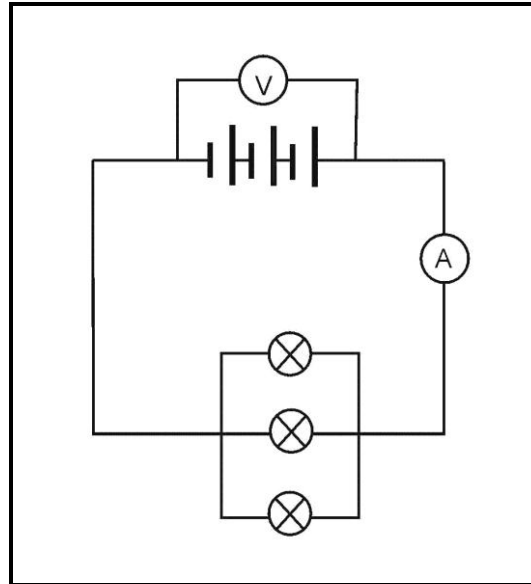

- 7.1 The three cells transfer 90 J of energy to 20 C of charge.
- 7.1.1 Define the term *voltage*. (2)
- 7.1.2 Calculate the voltage of all three cells. (3)
- 7.1.3 What would the potential difference of each cell be? (2)
- 7.2 A charge of 30 C passes a point in the main circuit in 40 s.
- 7.2.1 Determine the ammeter reading in this circuit. (3)
- 7.2.2 Determine the effective resistance of the parallel combination of resistors. (3)
- 7.3 If one of the light bulbs burns out, how would the brightness of the other two bulbs be affected? Write only BRIGHTER, DIMMER or NO CHANGE. (1)
- 7.4 Briefly explain your answer to Question 7.3. (2)
- [16]**

TOTAL SECTION B: 80

TOTAL 100

DATA FOR PHYSICAL SCIENCES GRADE 10
PAPER 1 (PHYSICS)

TABLE 1: PHYSICAL CONSTANTS

NAME	SYMBOL	VALUE
Speed of light in a vacuum	c	$3,0 \times 10^8 \text{ m}\cdot\text{s}^{-1}$
Plank's constant	h	$6,63 \times 10^{-34} \text{ J}\cdot\text{s}$
Charge on electron	e	$-1,6 \times 10^{-19} \text{ C}$
Electron mass	m_e	$9,11 \times 10^{-31} \text{ kg}$

TABLE 2: FORMULAE
WAVES, SOUND AND LIGHT

$v = f\lambda$	$f = \frac{1}{T}$ or $T = \frac{1}{f}$
$E = hf = \frac{hc}{\lambda}$	

ELECTRIC CIRCUITS

$V = \frac{W}{Q}$	$I = \frac{Q}{\Delta t}$
$R_s = R_1 + R_2 + \dots$	$\frac{1}{R_p} = \frac{1}{R_1} + \frac{1}{R_2} + \dots$

END