



**GAUTENG DEPARTMENT OF EDUCATION
PROVINCIAL EXAMINATION
JUNE 2019
GRADE 10**

**PHYSICAL SCIENCES
PAPER 1**

TIME: 1½ hours

MARKS: 100

10 pages, 1 data sheet and 1 graph paper

GAUTENG DEPARTMENT OF EDUCATION

PROVINCIAL EXAMINATION

PHYSICAL SCIENCES

TIME: 1½ hours

MARKS: 100

INSTRUCTIONS

1. Write your name in the appropriate space on the ANSWER BOOK.
2. This question paper consists of **6** questions. Answer ALL the questions.
3. Remove the graph paper, page 12 and hand it in with your ANSWER BOOK.
4. You may use a non-programmable calculator.
5. You may use appropriate mathematical instruments.
6. **YOU ARE ADVISED TO USE THE ATTACHED DATA SHEETS.**
7. Number the answers correctly according to the numbering system used in this question paper.
8. Write neatly and legibly.
9. Start EACH question on a NEW page in the ANSWER BOOK.
10. Leave ONE line between two sub-questions, for example between QUESTION 2.1 and QUESTION 2.2.
11. Show ALL formulae and substitutions in ALL calculations.
12. Round off your FINAL numerical answers to a minimum of TWO decimal places where needed.
13. Give brief motivations, discussions, et cetera where required.

SECTION A

QUESTION 1: MULTIPLE-CHOICE QUESTIONS

Four options are provided as possible answers to the following questions. Each question has only ONE correct answer. Write only the letter (A-D) next to the question number (1.1-1.10) on the answer sheet. Each answer counts TWO MARKS.

1.1 What is the magnitude of the angle between the direction of the disturbance and the direction of propagation of a transverse wave?

- A 0°
- B 45°
- C 90°
- D 180°

(2)

1.2 The diagram shows two waves travelling in the same medium for the same length of time.

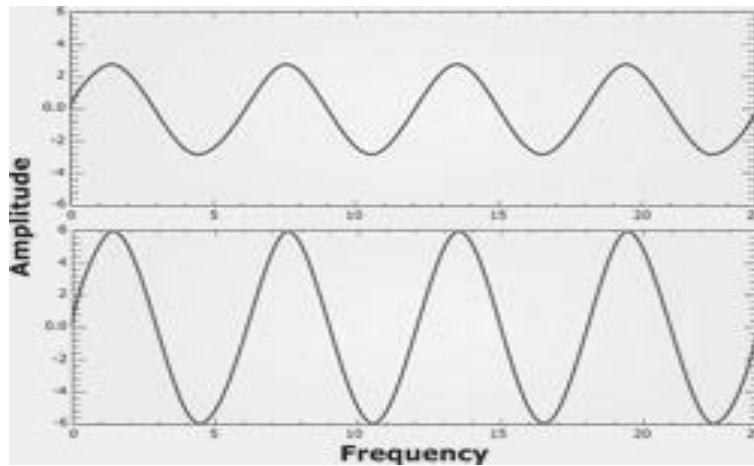

The two waves have different...

- A amplitudes.
- B speeds.
- C energies.
- D frequencies.

(2)

- 1.3 Two points on a transverse wave that have the same magnitude of displacement from equilibrium are said to be in phase if these points also have the ...
- A same direction of displacement and the same direction of motion.
 - B same direction of displacement and the opposite direction of motion.
 - C opposite direction of displacement and the same direction of motion.
 - D opposite direction of displacement and the opposite direction of motion. (2)
- 1.4 If two charges are identical with one having a charge Q , and they are brought together to touch each other and are then separated. The new charge on each will be...
- A Q .
 - B $2Q$.
 - C $\frac{1}{2}Q$.
 - D $4Q$. (2)
- 1.5 The region in a space where a magnetic material will experiences a force is called a/an ...
- A charge.
 - B electric field.
 - C magnetic field.
 - D magnetic flux. (2)
- 1.6 Which one of the following is equal to $10 \text{ C}\cdot\text{s}^{-1}$?
- A 10 V
 - B 10 A
 - C 10Ω
 - D 10 nC (2)
- 1.7 For which ONE of the quantities below is the CORRECT unit of measurement for the given quantity?

| | QUANTITY | UNIT |
|---|----------------------|------------------------------|
| A | Current | $\text{A}\cdot\text{s}^{-1}$ |
| B | Energy | kW |
| C | Potential difference | V |
| D | Resistance | $\text{V}\cdot\text{s}$ |

1.8 Consider the following statements concerning ultraviolet radiation:

- (i) It can be reflected.
- (ii) It has a longer wavelength than gamma rays.
- (iii) It is radiated from the sun and may be harmful to humans.

- A (i) and (ii) only
- B (ii) and (iii) only
- C (i) and (iii) only
- D (i), (ii) and (iii)

1.9 Choose the CORRECT combinations below concerning the pitch and loudness of sound.

The pitch and loudness of sound depend on:

| | PITCH | LOUDNESS |
|---|------------------------|------------------------|
| A | Frequency | Amplitude of vibration |
| B | Frequency | Speed of vibration |
| C | Amplitude of vibration | Frequency |
| D | Speed of vibration | Frequency |

1.10 Two pulses travel towards each other as shown in the diagram. When they meet, the resultant displacement and type of interference will be:

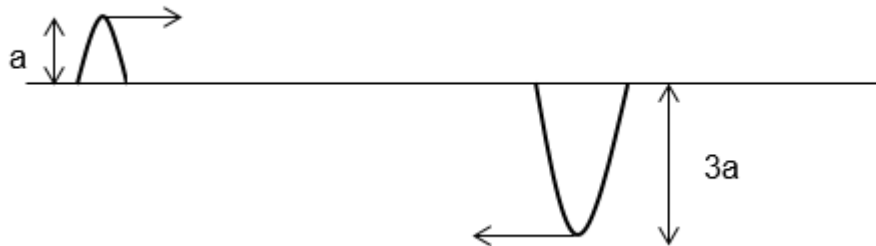

| | RESULTANT DISPLACEMENT | TYPE OF INTERFERENCE |
|---|-------------------------------|-----------------------------|
| A | $4a$ | Constructive |
| B | $2a$ | Constructive |
| C | $-2a$ | Destructive |
| D | $-4a$ | Destructive |

[20]

SECTION B
QUESTION 2

2.1 The diagram below shows two waves A and B of the same wavelength but different amplitudes crossing each other.

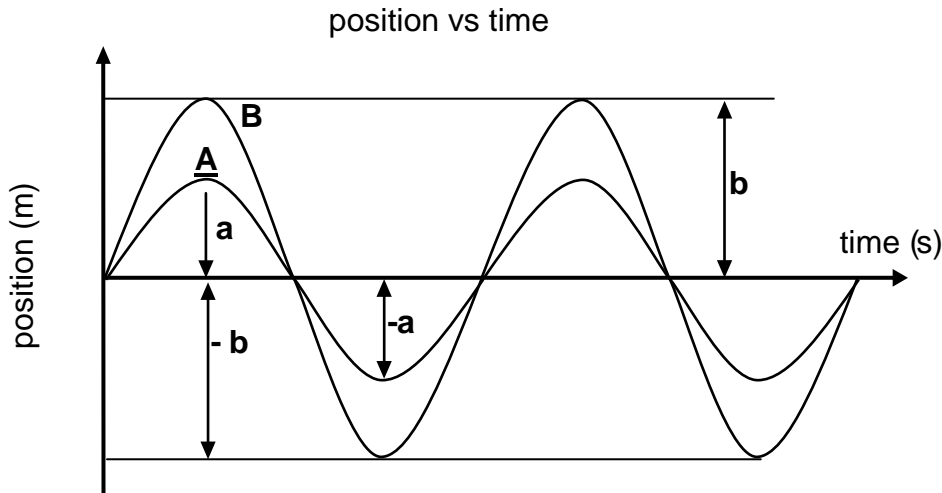

2.1.1 Define the term *wavelength*. (2)

2.1.2 Draw the shape of the resulting wave as the two waves **A** and **B** cross. On your diagram show the resulting amplitude. (4)

2.1.3 Which wave property is illustrated in QUESTION 2.1.2? (2)

2.1.4 State the principle used to answer QUESTION 2.1.2. (2)

2.2 In the sketch below, not drawn to scale, **Q** represents an object on the surface of the water in a dam. A person standing on a bridge observes object **Q** moving up and down. Object **Q** rises to the top every 5 s.

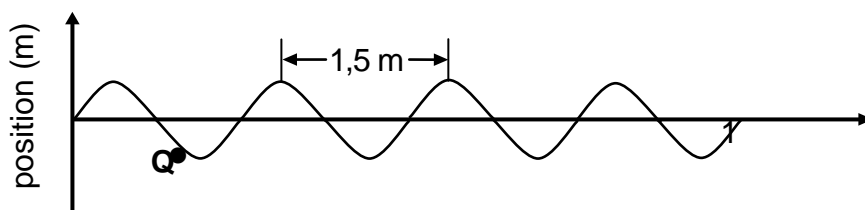

2.2.1 Define the term *period of a wave*. (2)

2.2.2 In which direction is object **Q** about to move? Write only UPWARDS or DOWNWARDS. (2)

2.3 Calculate the ...

2.3.1 frequency of the waves. (4)

2.3.2 speed of the waves. (4)

[22]

QUESTION 3

A section of the sound wave produced by a musical instrument is shown below.

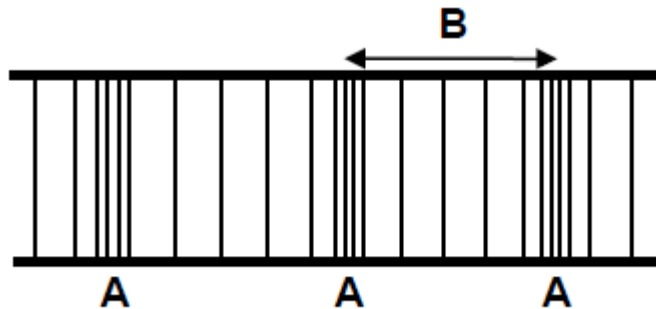

- 3.1 Define the term, *pulse*. (2)
- 3.2 Identify the components of the wave labelled
- 3.2.1 B (1)
- 3.2.2 A (1)
- 3.3 The highest frequency that a normal human ear can hear is about 20 kHz. A special whistle known as the silent whistle is used to train dogs.



- 3.3.1 If the whistle produces sound waves of wavelength 9 mm, determine, by calculation, whether the human ear will hear the sound produced by this whistle. Take the speed of sound in air to be $342 \text{ m}\cdot\text{s}^{-1}$. (5)
- 3.3.2 Name the type of sound produced by the silent whistle. (1)
- 3.4 A sound emitting device is placed between two buildings **A** and **B**, as shown below.



A sound wave emitted from the device strikes building A perpendicularly and returns to the device after 1,0s.

A second sound wave strikes building B perpendicularly and returns to the device after 1,5s. If the speed of sound in air at that point is $340 \text{ m}\cdot\text{s}^{-1}$, calculate the distance between the two buildings.

(6)
[16]

QUESTION 4

4.1 Radio waves are observed to have a wavelength of 0,14 m.

4.1.1 Give ONE use of radio waves in technology. (1)

4.1.2 Calculate the energy of a photon of these radio waves. (4)

4.2 An athlete breaks his leg while jogging and goes to have X-rays taken. X-rays emitted by the x-ray machine have a wavelength of $1,5 \times 10^{-11}$ m.



4.2.1 At what speed do X-rays travel? (1)

4.2.2 Calculate the frequency of the wave. (2)

4.3 *Overexposure to X-rays can be potentially dangerous.* Provide a reasons for this statement. (2)

[10]

QUESTION 5

- 5.1 Two insulated, graphite-coated polystyrene spheres **A** and **B** are suspended from threads. The spheres are held apart at a small distance. The charges on the spheres **A** and **B** are -8 C and $+20\text{ C}$, respectively. When the spheres are released they move towards each other.

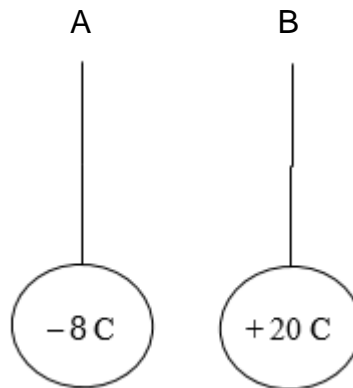

- 5.1.1 Explain why the spheres move towards each other when they are released. (2)
- 5.1.2 Which one of the two spheres has excess electrons? Write down SPHERE A or SPHERE B. (1)
- 5.2 The two spheres are allowed to touch each other and then separate.
- 5.2.1 Calculate the charge on each sphere after contact. (3)
- 5.2.2 Will the force now be one of ATTRACTION or REPULSION? Give a reason for your answer. (2)
- 5.2.3 State the *principle of quantisation of charge*. (2)
- 5.2.4 Determine the number of electrons transferred between the two spheres during contact. (4)
- (14)**

QUESTION 6

- 6.1 Consider the circuit below. When the switch is open and a voltmeter is connected across the battery it reads the *emf* of the battery. When the switch is closed, ammeter A_1 reads 5A and ammeter A_2 reads 3 A.

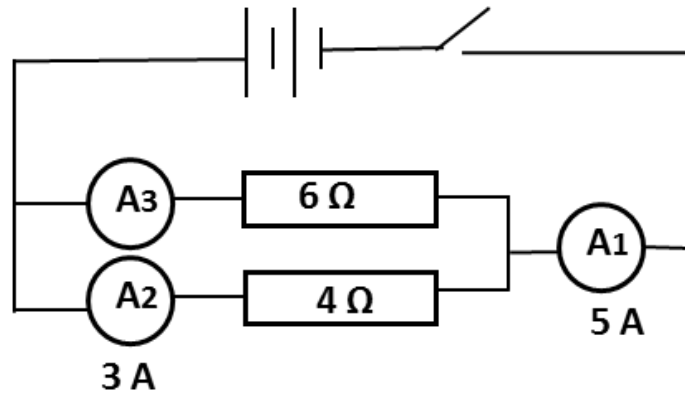

- 6.1.1 Define *emf* of a battery. (2)
 6.1.2 Calculate the effective resistance of the combination of the two resistors. (3)
 6.1.3 What will be the reading on ammeter A_3 when the switch is closed? (3)

Consider the circuit below. When the switch is closed, voltmeter V_1 reads 4V, V_2 reads 1.6 V and voltmeter V_4 reads 1 V.

6.2

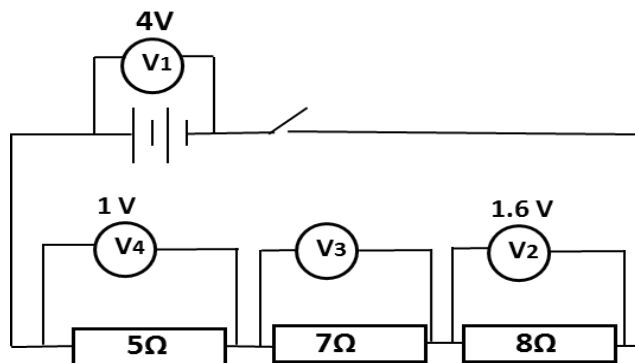

- 6.2.1 Calculate the effective resistance of the combination of the three resistors. (3)
 6.2.2 Determine the voltmeter reading on V_3 when the switch is closed. (2)
 6.2.3 If the current passing through the 8 Ω resistor is 0,2 A, what will the current through 5 Ω resistor be? Explain. (2)
- 6.3 A charge of 48 C flows through a circuit in 2 minutes. Calculate the current flowing through the circuit. (3)

[18]

TOTAL: 100

DATA FOR PHYSICAL SCIENCES GRADE 10
PAPER 1 (PHYSICS)

GEGEWENS VIR FISIESTE WETENSKAPPE GRAAD 10
VRAESTEL 1 (FISIKA)

TABLE 1: PHYSICAL CONSTANTS / TABEL 1: FISIESTE KONSTANTES

| NAME / NAAM | SYMBOL / SIMBOOL | VALUE / WAARDE |
|---|------------------|---|
| Speed of light in a vacuum <i>Spoed van lig in 'n vakuum</i> | C | $3,0 \times 10^8 \text{ m}\cdot\text{s}^{-1}$ |
| Plank's constant <i>Plank se konstante</i> | h | $6,63 \times 10^{-34} \text{ J}\cdot\text{s}$ |
| Charge on electron <i>Lading op elektron</i> | e | $-1,6 \times 10^{-19} \text{ C}$ |
| Electron mass <i>Elektronmassa</i> | m_e | $9,11 \times 10^{-31} \text{ kg}$ |

TABLE 2: FORMULAE / TABEL 2: FORMULES
WAVES, SOUND AND LIGHT / GOLWE, KLANK EN LIG

| | |
|-------------------------------|---|
| $v = f\lambda$ | $f = \frac{1}{T}$ or/of $T = \frac{1}{f}$ |
| $E = hf = \frac{hc}{\lambda}$ | |

ELECTRIC CIRCUITS / ELEKTRIESE STROOMBANE

| | |
|---------------------------|---|
| $V = \frac{W}{Q}$ | $I = \frac{Q}{\Delta t}$ |
| $R_s = R_1 + R_2 + \dots$ | $\frac{1}{R_p} = \frac{1}{R_1} + \frac{1}{R_2} + \dots$ |

NAME: _____

CLASS: _____

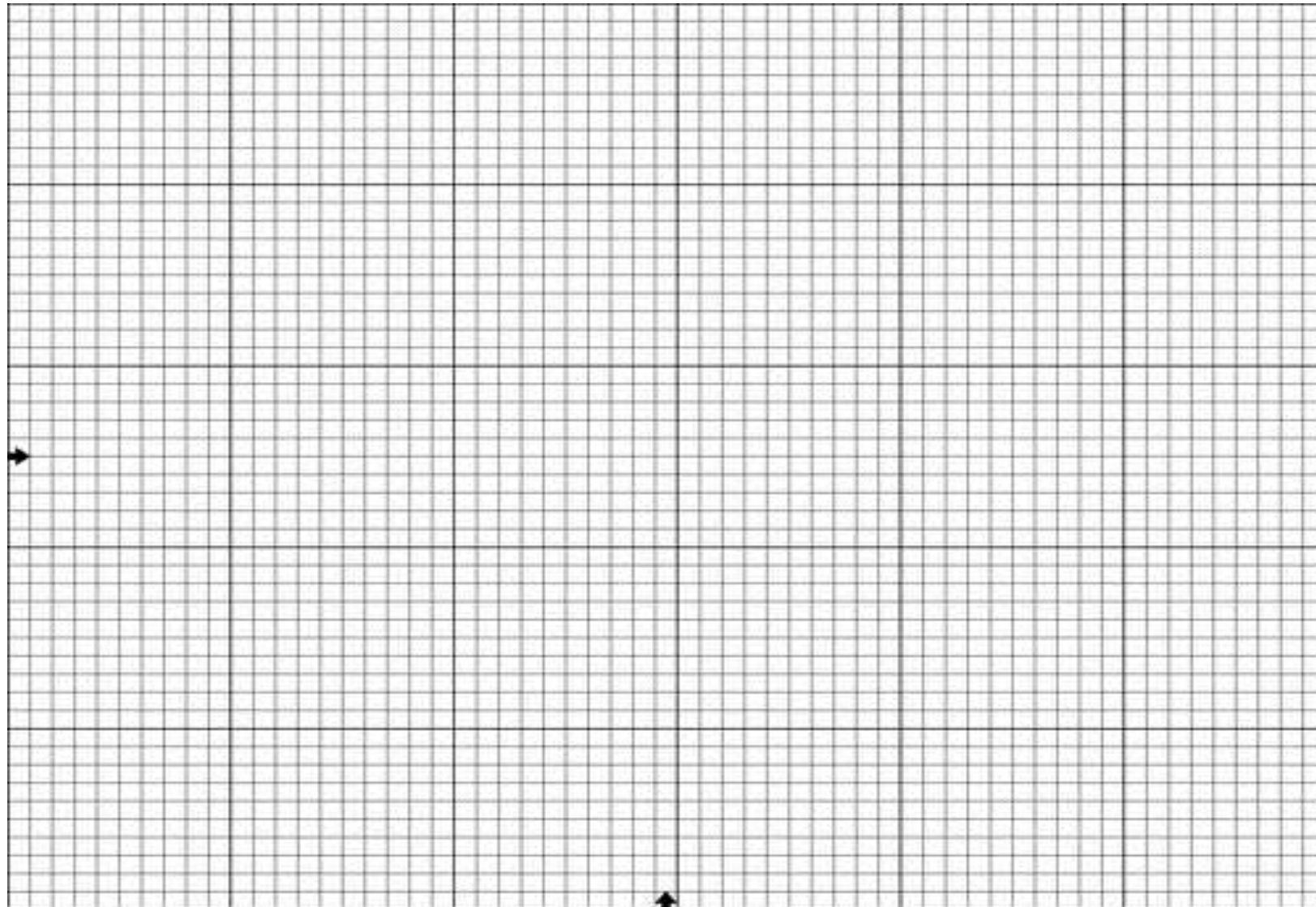

END