

**NATIONAL  
SENIOR CERTIFICATE**

**GRADE 10**

**NOVEMBER 2019**

**PHYSICAL SCIENCES (PHYSICS) P1  
(EXEMPLAR)**

**MARKS: 150**

**TIME: 2 hours**

---

This question paper consists of 18 pages, including an answer sheet and a data sheet.

---



**INSTRUCTIONS AND INFORMATION**

1. Write your NAME and SURNAME in the appropriate space on the ANSWER BOOK.
2. This question paper consists of ELEVEN questions. Answer ALL the questions in the ANSWER BOOK.
3. Start EACH question on a NEW page in the ANSWER BOOK.
4. Number the question correctly according to the numbering system used in this question paper.
5. Leave ONE line between two sub questions, for an example, between QUESTION 2.1 and QUESTION 2.2.
6. You may use a non-programmable calculator.
7. You may use appropriate mathematical instrument.
8. Show ALL formulae and substitution in your calculations.
9. Round off your final answers to a minimum of TWO decimal places.
10. Give brief motivations, discussions etcetera where required
11. You are advised to use the attached DATA SHEET.
12. Write neatly and legibly.

**QUESTION 1: MULTIPLE-CHOICE QUESTIONS**

Various options are provided as possible answers to the following questions. Choose the answer and write only the letter (A–D) next to the question number (1.1–1.10) in the ANSWER BOOK, for example 1.11 D.

1.1 Which ONE of the following has both magnitude and direction?

- A Speed
- B Vectors
- C Scalars
- D Distance (2)

1.2 The straight line distance between two points with direction is called ...

- A speed.
- B velocity.
- C acceleration.
- D displacement. (2)

1.3 The table below shows the changes in the velocity of a car in intervals of 2 seconds.

|                                    |   |   |    |    |    |    |    |    |    |
|------------------------------------|---|---|----|----|----|----|----|----|----|
| <b>Time (s)</b>                    | 0 | 2 | 4  | 6  | 8  | 10 | 12 | 14 | 16 |
| <b>Velocity (m.s<sup>-1</sup>)</b> | 0 | 5 | 10 | 15 | 20 | 20 | 20 | 20 | 20 |

Which ONE of the following is CORRECT about the acceleration of the car?

The **acceleration** of the car ...

- A increases initially for 8 s then remains constant.
- B is initially constant for 8 s then becomes zero.
- C is initially constant for 8 s and then decreases.
- D increases initially for 8 s and then becomes zero. (2)

- 1.4 A position-time graph for an object travelling along a straight horizontal surface is shown below.

GRAPH OF POSITION VERSUS TIME

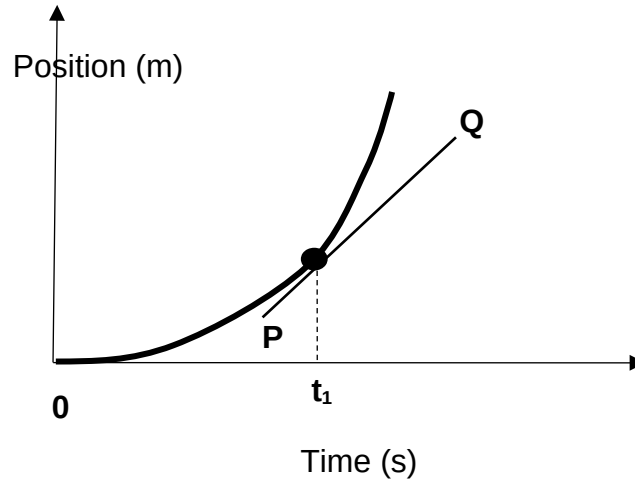

Line **PQ** is a tangent to the curve at  $t_1$ .

Which ONE of the following is equal to the gradient of **PQ**?

- A Average velocity over the period **0** to  $t_1$
  - B Instantaneous velocity at  $t_1$
  - C Average acceleration over the period **0** to  $t_1$
  - D Instantaneous acceleration at  $t_1$  (2)
- 1.5 An object starts moving from a position of rest with a constant acceleration **a**. After covering a distance  $\Delta x$ , the velocity is **v**.

What will its velocity be after it has covered a distance of  $2\Delta x$ ?

- A  $v/2$
- B  $\sqrt{2v}$
- C  $2v$
- D  $4v$  (2)

- 1.6 A block is dropped from rest at point **P** and falls vertically downwards to point **Q**. The same block is also allowed to slide from rest at point **P** along two different slopes **PR** and **PS** as shown in the diagram below.

Ignore air friction.

Points **Q**, **R** and **S** are on the ground.

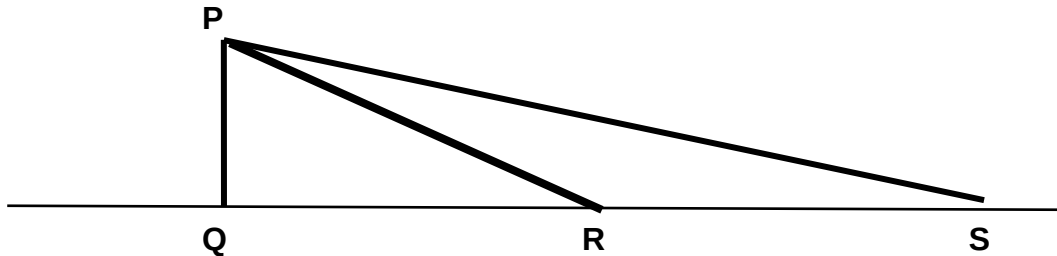

Along which path will the block reach the ground at the highest speed?

- A **PQ**  
 B **PR**  
 C **PS**  
 D The speed of the block will be the same at all the points **PQ**, **PR** and **PS** (2)
- 1.7 Two magnets are brought closer to each other as shown in the diagram below.

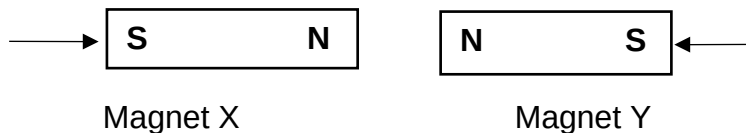

What will happen to the magnitude of the force that magnet **X** exerts on magnet **Y** as the magnets are brought closer?

The magnitude of the force ...

- A increases.  
 B decreases.  
 C remains the same.  
 D becomes zero. (2)

1.8 Consider the diagram of two pulses shown below.

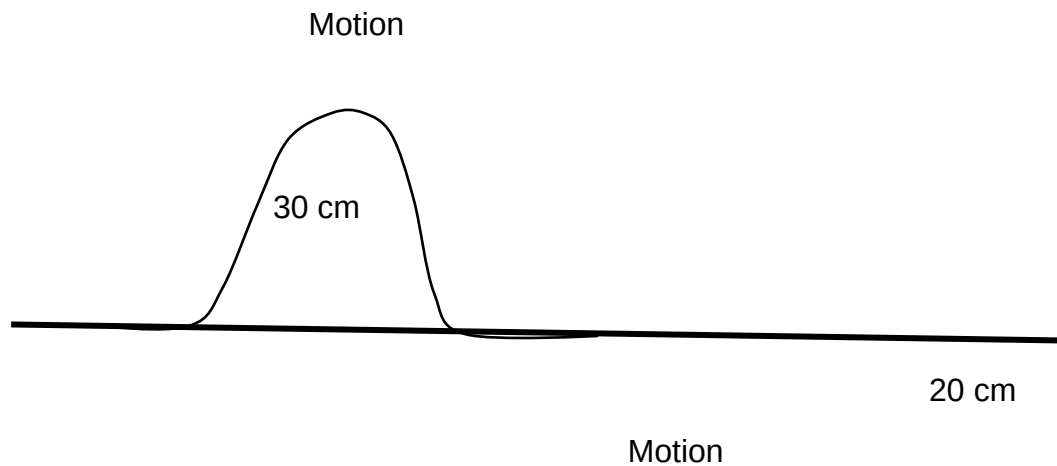

When the two pulses in the diagram meet at point X, the type of interference and the resultant amplitude of the disturbance will be ...

|   | TYPE OF INTERFERENCE | AMPLITUDE (cm) |
|---|----------------------|----------------|
| A | Destructive          | 10             |
| B | Destructive          | 50             |
| C | Constructive         | 10             |
| D | Constructive         | 50             |

(2)

1.9 A balloon is brought closer to a positively charged sphere as shown in the diagram below.

The balloon is attracted to the sphere.

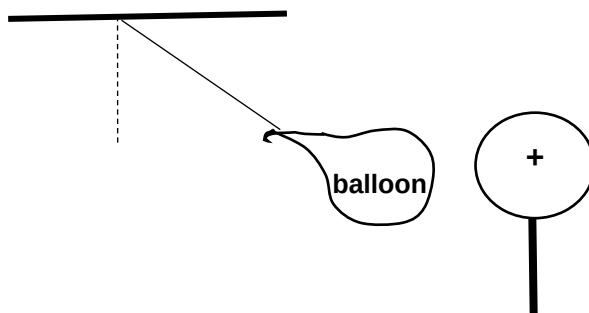

Which ONE of the following is the type of charge on the balloon?

- A Positive
- B Positive or neutral
- C Negative or neutral
- D Negative or positive

(2)

1.10 The opposition to flow of electric charge is called ...

- A EMF.
- B resistance.
- C electric current.
- D potential difference.

(2)  
[20]

## QUESTION 2

A girl walks from her home at point **A** to a shop located at point **B**. On her return she stops at a friend's house at point **C**.

The girl walks on a flat horizontal surface past houses with yards that are squares of 20 m length each, as shown in the diagram.

She completes the motion from point **A** to point **C** in 300 s.

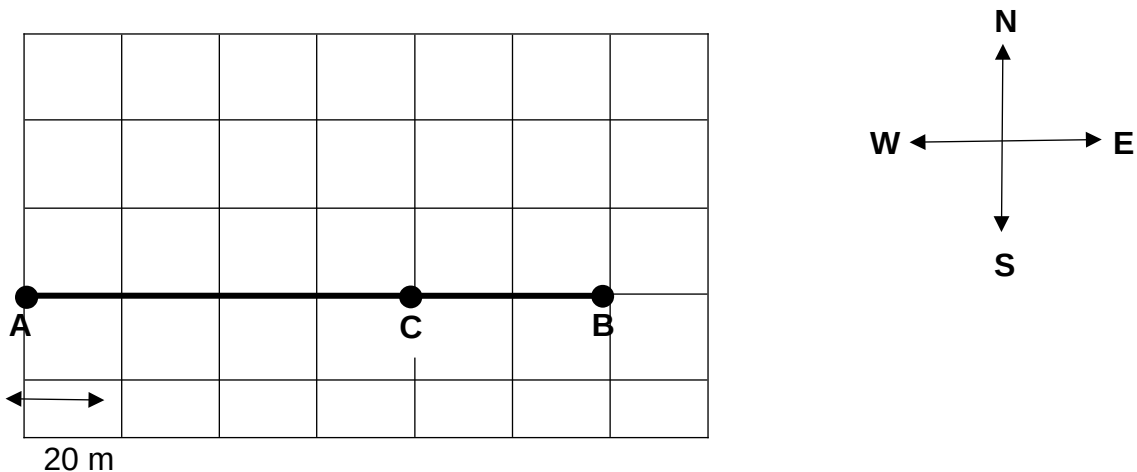

Point **B** and **C** are both **east** of point **A**.

2.1 Define the term *resultant vector*. (2)

2.2 Use a vector scale diagram to determine the girl's displacement for the whole motion.

Scale 1 cm : 20 m (5)

2.3 For the motion of the girl from point **A** to **C**, calculate the:

2.3.1 Total distance covered (2)

2.3.2 Girl's average speed (3)

[12]

**QUESTION 3**

The velocity-time graph of a car initially moving **north** is shown below.

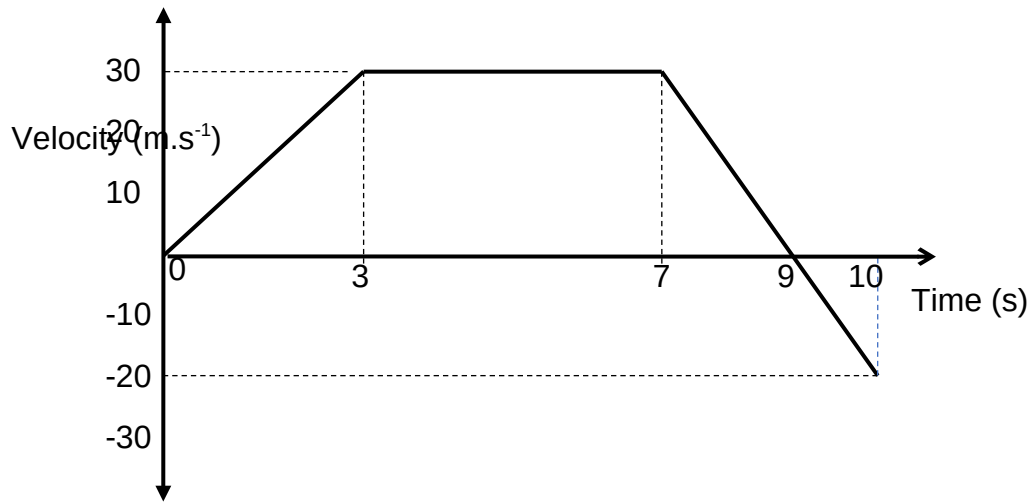

3. Define *acceleration*.

1

(2)

Use information from the graph to answer QUESTIONS 3.2 and 3.3.

3. Write down the:

2

3.2.1 Speed of the car at  $t = 9$  s

(1)

3.2.2 Direction of motion of the car after 9 s

(1)

3.2.3 Magnitude of the acceleration of the car during the interval of 3 s to 7 s

(1)

3. Without the use of equations of motion, calculate the:

3

3.3.1 Magnitude of the acceleration of the car during the first 3 s

(4)

3.3.2 Total displacement

(6)

**[15]**

**QUESTION 4**

4.1 A car initially at rest moves with a constant acceleration of  $2 \text{ m}\cdot\text{s}^{-2}$  east.

Calculate the:

4.1.1 Magnitude of the velocity after 10 s (3)

4.1.2 Distance covered during the first 10 s (3)

4.2 An airplane has an unknown initial velocity. After travelling a distance of 3 500 m while accelerating at a constant acceleration of  $5 \text{ m}\cdot\text{s}^{-2}$  it doubles its velocity.

Calculate the time it took to double the velocity. (6)

**[12]**

**QUESTION 5**

A toy car of mass 2 kg moves past point **A**, which is 30 m above the ground at a speed of  $10 \text{ m}\cdot\text{s}^{-1}$ . The path **ABC** is frictionless.

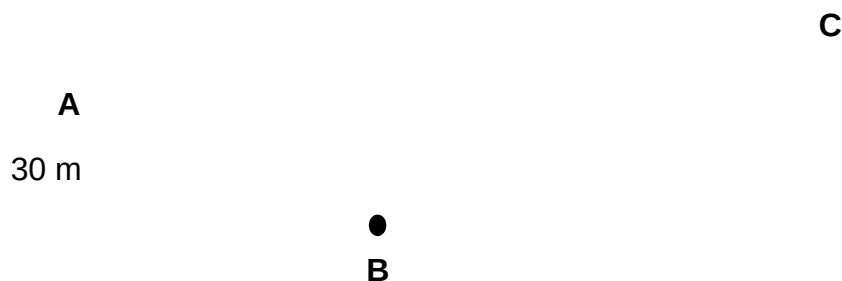

Point **B** is on the ground.

5. Write down a term for the following definition:

1

*“The sum of kinetic energy and potential energy of a body.”* (1)

5. Calculate the sum of kinetic energy and potential energy of the toy car at point **A**. (4)

2

5. Determine by calculation the speed of the toy car at point **B**.

3

(4)

5. Name and state the Physics Law or Principle you used to answer QUESTION 5.3 above. (3)

4

5. The table shown below gives the kinetic energy values and the corresponding heights of the toy car

5

| Height (m) | Kinetic energy (J) |
|------------|--------------------|
| 30         | 100                |
| 25         | 198                |
| 20         | 296                |
| 15         | 394                |

Use the values in the table and the supplied graph paper to draw a graph of height versus kinetic energy (on vertical axis).

(3)

**[15]**

## QUESTION 6

The diagram below shows a wave pattern of a wave train with a frequency of 30 Hz.

This wave is moving  
in this direction

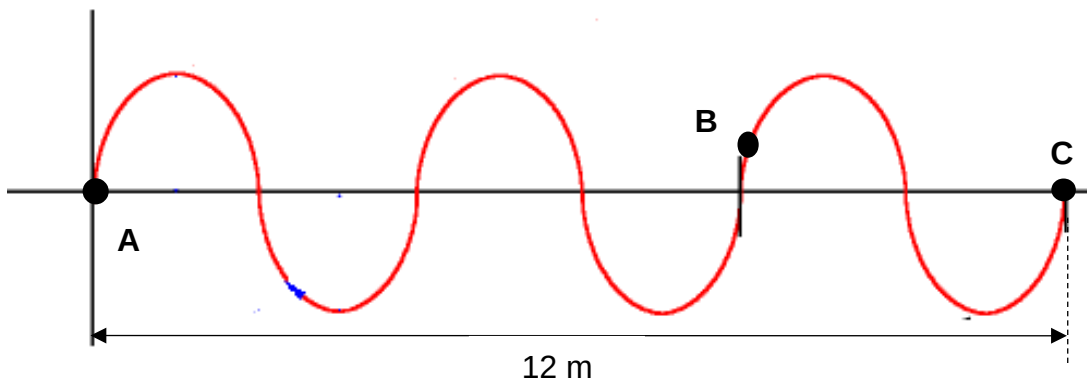

6. Define the term *pulse*. (2)

1

6. In which direction is the particle at point **B** about to move?

2

Write down UP or DOWN.

(1)

6. Calculate the:

3

6.3.1 Time that lapsed while the wave moved from **A** to **C**

(4)

6.3.2 Wavelength of the wave

(2)

6.3.3 Speed of the wave

(3)

[12]

**QUESTION 7**

Thembi stands 85 m from a high wall while she is beating a drum. She notices that the echo of each beat coincides exactly with the next beat of the drum if she strikes the drum every 0,5 s.



7.1 Use the information given above to calculate the following:

7.1.1 The speed of sound in the air (3)

7.1.2 The wavelength of the sound waves, if the drumhead vibrates at 100 Hz (3)

7.2 Ultrasound is often used in the medical field to examine the internal parts of the human body.

7.2.1 What is meant by *ultrasound*? (2)

7.2.2 Give ONE non-medical use of ultrasound. (1)

7.2.3 Why is ultrasound often preferred to other types of body scanning? (2)

**[11]**

**QUESTION 8**

Three types of electromagnetic radiations are given in the table below.

| Radiation   |
|-------------|
| X-rays      |
| Ultraviolet |
| Infra-red   |

8.1 Write down the NAME of:

8.1.1 The radiation with the longest wavelength from the given list (1)

8.1.2 ONE source of ultraviolet light (1)

8.2 Calculate the energy of a photon of infra-red if its wavelength is  $4 \times 10^{-5} \text{ m}$  (5)

8.3 Learners are investigating the penetrating ability of ultraviolet radiation and X-rays. They shine electromagnetic radiation (ultraviolet and X-rays) using identical bulbs onto a muscle tissue and a bone tissue as shown below.

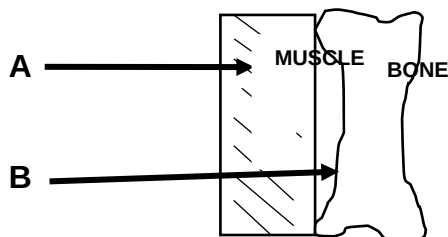

Rays of radiation **B** penetrate through the muscle tissue but they are stopped by the bone tissue. Rays of radiation **A** do not reach the bone tissue.

8.3.1 Which radiation (**A** or **B**) represents X-rays?  
Give a reason for your answer. (3)

8.3.2 Write down the independent variable for the investigation. (1)

8.3.3 Give a reason why it is necessary to use identical bulbs for the investigation. (2)

**[13]**

**QUESTION 9**

Consider magnet **A** placed on a surface as shown below.

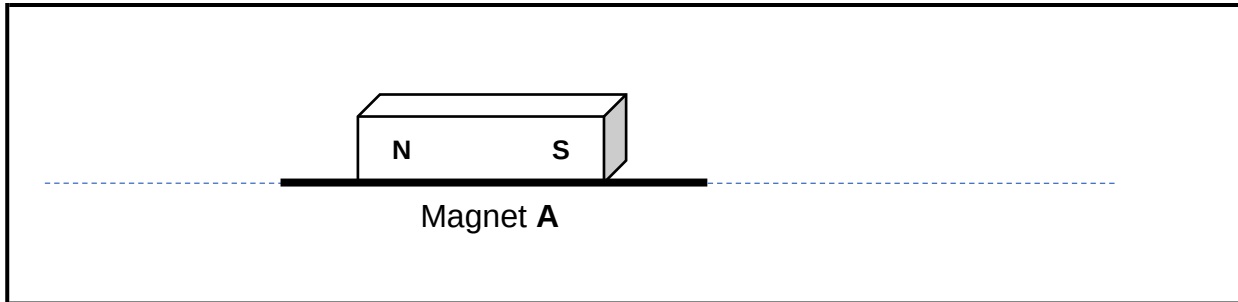

9.1 Draw the magnetic field pattern around the magnet.

The north pole of another magnet **B** is brought closer to the south pole of magnet **A**.

(3)

9.2 What is the nature of the force between magnets **A** and **B**?

Write down ATTRACTION or REPULSION.

(1)

9.3 Magnet **A** is cut in the middle into TWO pieces **X** and **Y** as shown below.

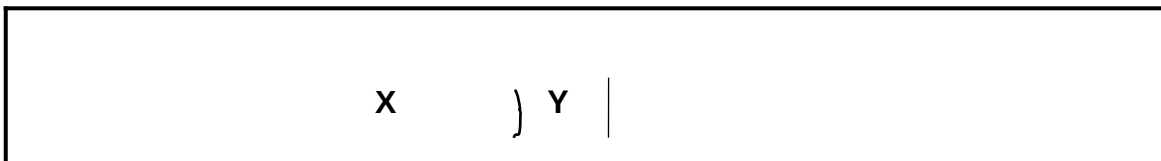

9.3.1 Does piece **X** have both South and North pole?

Write down Yes or No.

(1)

9.3.2 The two cut sections of pieces **X** and **Y** are pushed back in an attempt to form the original piece, magnet **A**.

Will the two pieces attach to each other when pushed back together and released? (Yes or No)

Explain the answer.

(2)

9.4 Explain how Earth's magnetic field provides protection against solar winds.

(2)

**[9]**

**QUESTION 10**

Two identical metal spheres **A** and **B** are placed on insulated stands. Spheres **A** and **B** carry charges of  $+4,4 \text{ nC}$  and  $-2 \text{ nC}$  respectively.

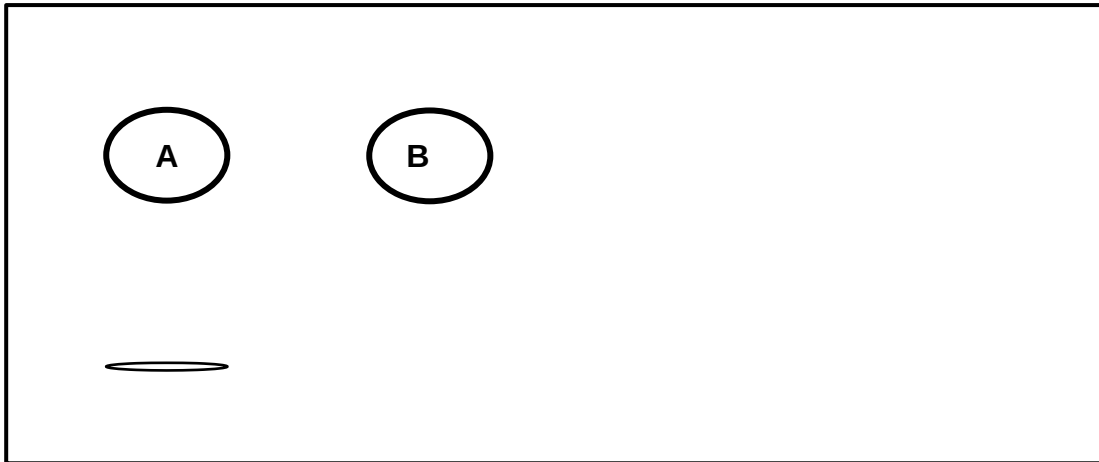

10. Which sphere (**A** or **B**) has FEWER electrons?  
1 (1)
10. Write down the NAME of the type of FIELD around the charged spheres.  
2 Choose from MAGNETIC, ELECTRIC or GRAVITATIONAL. (1)
10. Give a reason why the charged spheres are placed on insulated stands.  
3 (2)
10. The spheres are brought into contact and then separated as shown below.  
4

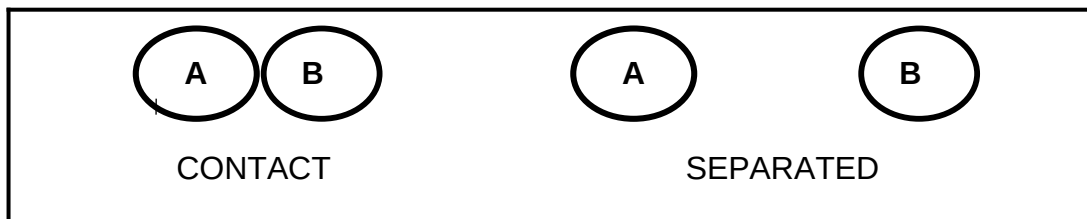

- 10.4. State the principle of conservation of charge.  
1 (2)
- 10.4. Which sphere loses electrons when the two spheres come into contact?  
2 (1)
- 10.4. Calculate how many electrons transferred from one sphere to the other when they come into contact.  
3 (5)
- [12]**  
**]**

**QUESTION 11**

The circuit diagram shows a circuit consisting of a battery of negligible resistance, two ammeters also of negligible resistance, three resistors and two high resistance voltmeters.

The reading on **A<sub>1</sub>** is **1A**.

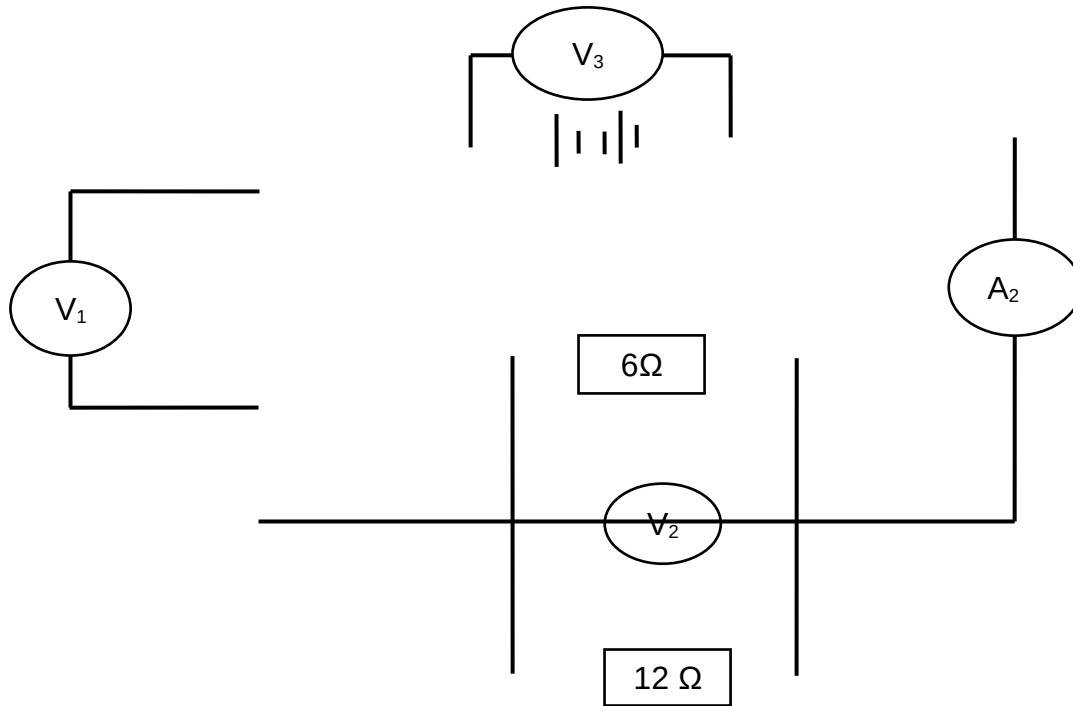

- 11.1 Define the term *electric current*. (2)
- 11.2 Complete the following sentence by filling in the missing words.  
Resistors in series divide (11.2.1) ... and resistors in parallel divide (11.2.2) ... (2)
- 11.3 Calculate the:
  - 11.3.1 Effective resistance of the parallel combination of resistors (3)
  - 11.3.2 Total resistance of the circuit (2)
  - 11.3.3 Amount of charge passing through ammeter **A<sub>2</sub>** in 5 seconds (5)
- 11.4 How does the potential difference across the 6 Ω resistor compare to the potential difference across the 12 Ω resistor?  
Write down only LESS THAN, GREATER THAN OR EQUAL TO.  
Give a reason for the answer. (3)
- 11.5 If the 6 Ω-resistor 'burns out' will the total resistance of the circuit INCREASE, DECREASE or REMAIN THE SAME? (2)

TOTAL: 150

NAME AND SURNAME: \_\_\_\_\_

CLASS: \_\_\_\_\_

Graph of height vs Kinetic energy

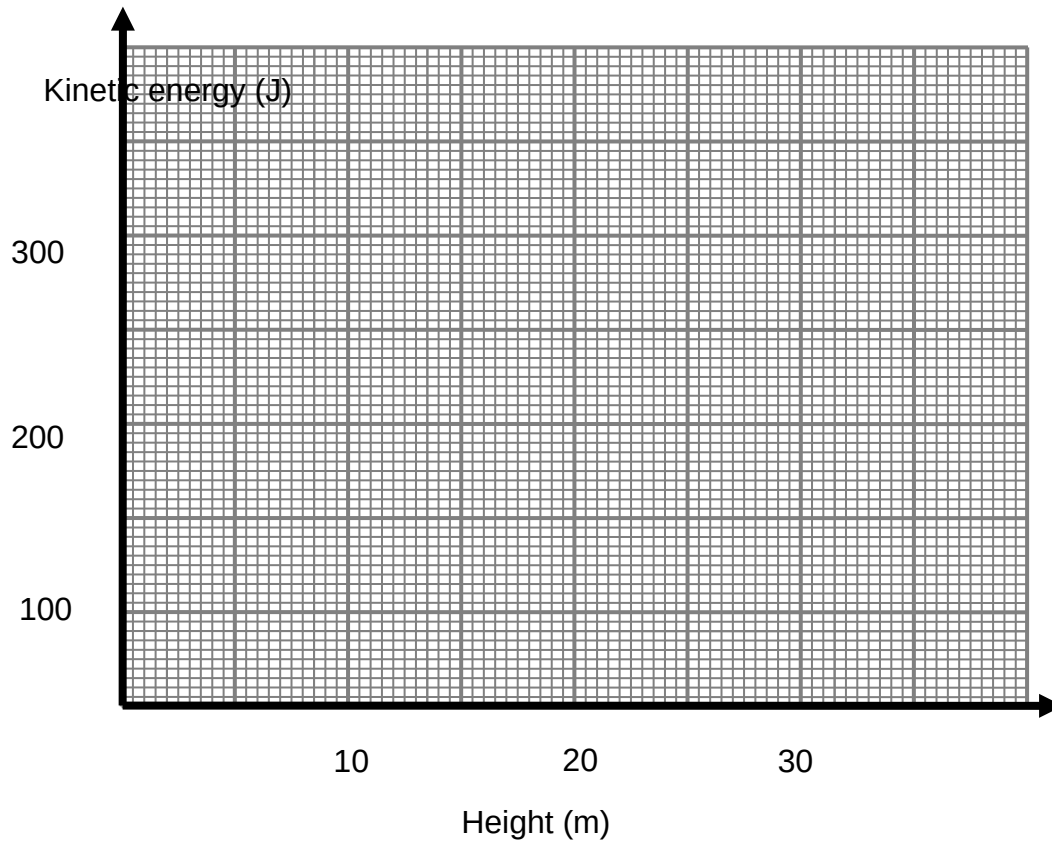

**DATA FOR PHYSICAL SCIENCES GRADE 10**  
**DATA VIR FISIESTE WETENSAPPE GRAAD 10**  
**PAPER 1 (PHYSICS) / VRAESTEL 1 (FISIKA)**

**TABLE/TABEL 1: PHYSICAL CONSTANTS/FISIESTE KONSTANTES**

| NAME / NAAM  | SYMBOL / SIMBOOL | VALUE / WAARDE                                |
|--|------------------|---|
| Acceleration due to gravity<br><i>Versnelling as gevolg van gravitasie</i> | $g$              | $9,8 \text{ m}\cdot\text{s}^{-2}$             |
| Speed of light in a vacuum<br><i>Spoed van lig in 'n vakuum</i>            | $c$              | $3,0 \times 10^8 \text{ m}\cdot\text{s}^{-1}$ |
| Planck's constant<br><i>Planck se konstante</i>                            | $h$              | $6,63 \times 10^{-34} \text{ J}\cdot\text{s}$ |
| Charge on electron<br><i>Lading op elektron</i>                            | $e^-$            | $-1,6 \times 10^{-19} \text{ C}$              |

**TABLE/TABEL 2: FORMULAE / FORMULES****MOTION / BEWEGING**

|                          |  |                                |  |
|--------------------------|--|--------------------------------|--|
| $v_f = v_i + a \Delta t$ | $\Delta x = v_i \Delta t + \frac{1}{2} a \Delta t^2$ | $v_f^2 = v_i^2 + 2 a \Delta x$ | $\Delta x = \left( \frac{v_f + v_i}{2} \right) \Delta t$ |
|--------------------------|--|--------------------------------|--|

**WEIGHT AND MECHANICAL ENERGY / GEWIG EN MEGANIESE ENERIE**

|            |                 |                          |                                       |
|------------|-----------------|--------------------------|---------------------------------------|
| $F_g = mg$ | $U = E_p = mgh$ | $E_k = \frac{1}{2} mv^2$ | $E_m = (E_k + E_p)_i = (E_k + E_p)_f$ |
|------------|-----------------|--------------------------|---------------------------------------|

**WAVES, LIGHT AND SOUND / GOLWE, LIG EN KLANK**

|                         |                   |                                    |
|-------------------------|-------------------|------------------------------------|
| $v = f \lambda$         | $T = \frac{1}{f}$ | $E = hf$ $E = h \frac{c}{\lambda}$ |
| $\Delta x = v \Delta t$ | $n = \frac{c}{v}$ | $f \lambda$                        |

**ELECTRICITY AND MAGNETISM / ELEKTRISITEIT EN MAGNETISME**

|   |                           |                   |                           |
|---|---------------------------|-------------------|---------------------------|
| $I = \frac{Q}{\Delta t}$                                | $V = \frac{W}{Q}$         | $R = \frac{V}{I}$ | $Q = \frac{Q_1 + Q_2}{2}$ |
| $\frac{1}{R_p} = \frac{1}{R_1} + \frac{1}{R_2} + \dots$ | $R_s = R_1 + R_2 + \dots$ | $n = \frac{Q}{e}$ |                           |