



Education and Sport Development

Department of Education and Sport Development
Departement van Onderwys en Sportontwikkeling
Lefapha la Thuto le Tlhabololo ya Metshameko

NORTH WEST PROVINCE

NATIONAL SENIOR CERTIFICATE

GRADE 10

PHYSICAL SCIENCES

JUNE 2017

MARKS: 150

TIME : 2 hours

This question paper consists of 12 pages including a information sheet and periodic table.

INSTRUCTIONS AND INFORMATION

1. Write neatly and legibly.
2. Number the answers correctly according to the numbering system used in this question paper.
3. You may use a non-programmable calculator.
4. You may use appropriate mathematical instruments.
5. You are advised to use the attached DATA SHEETS.
6. Show ALL formulae and substitutions in ALL calculations.
7. Round off your final numerical answers to a minimum of TWO decimal places.

8. Give brief motivations, discussions, et cetera where required.

QUESTION 1 (MULTIPLECHOICE QUESTIONS)

Four options are provided as possible answers to the following questions. Each question has only ONE correct answer. Write only the letter (**A-D**) next to the question number (1.1-1.10) in the ANSWER BOOK, for example 1.11 **C**.

1.1 Pure air is a/an:

- A. element
- B. compound
- C. homogeneous mixture
- D. heterogeneous mixture (2)

1.2 The correct formula for the compound known as aluminium sulphate is?

- A $\text{Al}_3(\text{SO}_4)_2$
- B Al_2S_3
- C AlSO_4
- D $\text{Al}_2(\text{SO}_4)_3$ (2)

1.3 Consider the unbalanced equation below:

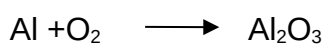

Which one of the following combinations correctly shows the coefficients of the reactants and the products in the balanced equation?

- | | Al | O ₂ | Al ₂ O ₃ | |
|---|----|----------------|--------------------------------|-----|
| A | 2 | 3 | 2 | |
| B | 4 | 3 | 2 | |
| C | 4 | 3 | 4 | |
| D | 1 | 3 | 2 | (2) |

- 1.4 When an atom X of an element in Group 1 reacts to become X^+ , the ...
- A mass number of X increases.
 - B atomic number of X decreases
 - C charge of the nucleus increases.
 - D number of filled energy levels decreases. (2)
- 1.5 The average kinetic energy of gas molecules is related to the:
- A volume of the gas.
 - B temperature of the gas.
 - C molecular formula of the gas
 - D number of gas molecules (2)
- 1.6 Which ONE of the following pairs of atoms is most likely to form an ionic bond?
- A N and F
 - B C and F
 - C Na and F
 - D O and F (2)
- 1.7 Which ONE of the following shows the different types of electromagnetic radiation in order of increasing frequency?
- A X-rays; ultraviolet rays; infrared rays; visible light
 - B Infrared rays; X-rays; visible light; ultraviolet rays
 - C Infrared rays; visible light; ultraviolet rays; X-rays
 - D X-rays; ultraviolet rays; visible light; infrared rays (2)

- 1.8 A tuning fork is made to vibrate by striking it gently on a rubber stopper.
The sound waves produced are ...
- A transverse waves and requires a medium for propagation.
 - B transverse waves and requires no medium for propagation.
 - C longitudinal waves and requires no medium for propagation.
 - D longitudinal waves and requires a medium for propagation. (2)
- 1.9 The magnitude of an electric current in an electric circuit will definitely increase if:
- A more cells are connected in parallel.
 - B more resistors are connected in series.
 - C the resistors are connected in parallel.
 - D the cells are parallel and the resistors are connected in series. (2)
- 1.10 Which one of the following material is attracted to a Magnet?
- A Sodium
 - B Cobalt
 - C Brass
 - D Silver (2)

[20]**QUESTION 2**

In everyday life we seldom come into contact with pure substances. The air that we breath, the water in rivers, lakes and oceans and Earth itself are all composed of mixtures of substances.

2.1 Define a pure substance. (2)

2.2 Decide whether the following substances are homogeneous or heterogeneous mixtures and explain your answer.

2.2.1 Sugar dissolved in water. (2)

2.2.2 Oil and water. (2)

2.3 Complete the following table:

Do not copy the table, write only the numbers (2.3.1- 2.3.8) and write the correct answer next to the number.

Chemical symbol	Chemical name	Number of protons	Number of neutrons	Number of electrons
Cl	2.3.1	2.3.2.	2.3.3.	2.3.4.
2.3.5.	Potassium	2.3.6.	2.3.7	2.3.8.

(8)

2.4 Study the diagram below and answer the questions that follow:



2.4.1 Distinguish between a thermal conductor and a thermal insulator. (4)

Which part/s of the pot in the diagram above is a

2.4.2 thermal conductors. (1)

2.4.3 thermal insulators. (1)

[20]

QUESTION 3

The following diagram represents a molecule of a certain gas.

- 3.1 Write down:
- 3.1.1 the name of this gas. (1)
- 3.1.2 formula of this gas. (2)
- 3.2 Define "ionic bonding". (2)
- 3.3 Chlorine is found in nature as a diatomic molecule Cl_2 and it reacts with sodium metal to form NaCl .
- 3.3.1 What type of bond is formed between chlorine and sodium atoms? (2)
- 3.3.2 Draw an Aufbau diagram for chloride ion (Cl^-). (5)
- 3.3.3 Name and state TWO rules/principles that you applied to answer QUESTION 3.3.2 above. (6)
- [18]**

QUESTION 4

Study the following diagram and answer the question that follows:

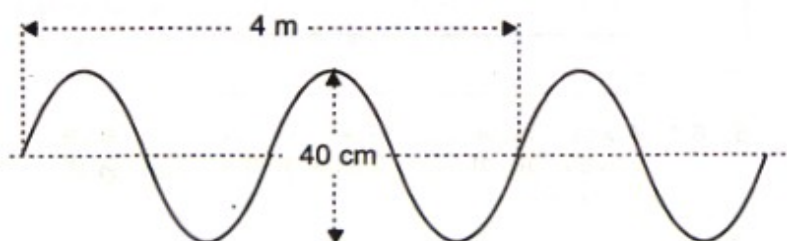

One complete wave was executed in 2 seconds.

- 4.1 Define a transverse pulse. (2)
- 4.2 What time does it take 8 waves to pass a particular point? (show your calculations) (2)
- 4.3 What is the period of the wave? (1)
- 4.4 Calculate the wavelength of this wave. (2)
- 4.5 Calculate the frequency of this wave. (3)
- 4.6 Calculate the speed of this wave. (3)
- [13]**

QUESTION 5

Study the following diagram carefully and answer the questions that follow:

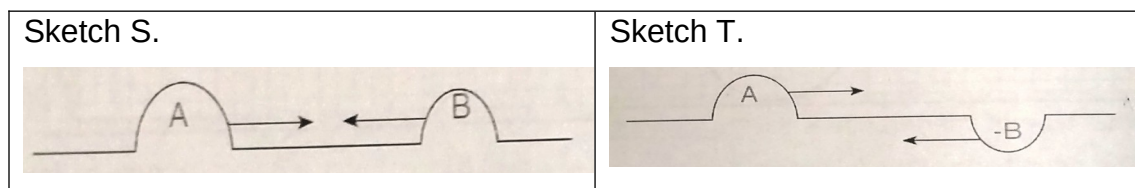

- 5.1 Define the principle of superposition of waves. (2)
- 5.2 Name the type of interference that will occur in:
- 5.2.1 sketch S. (1)
- 5.2.2 sketch T. (1)
- 5.3 Use a sketch diagram to illustrate resulting wave in:
- 5.3.1 sketch S. (3)
- 5.3.2 sketch T. (3)
- 5.4 Study the following diagram carefully and answer the questions that follows:

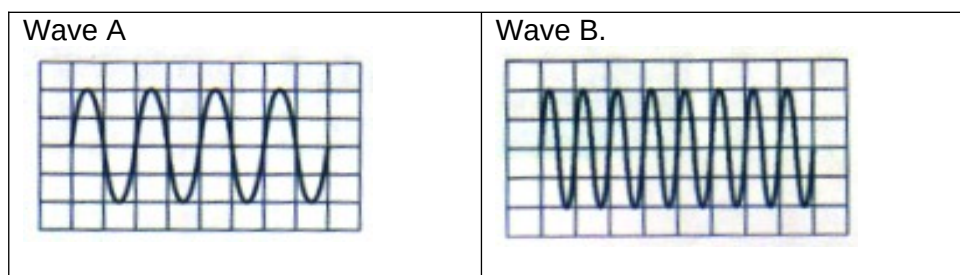

- 5.4.1 Which ONE of these waves, wave **A** or **B** has the highest pitch? (1)
- 5.4.2 Give a reason for your answer in QUESTION 5.4.1. (2)
- 5.5 Study the following diagram carefully and answer the questions that follows:

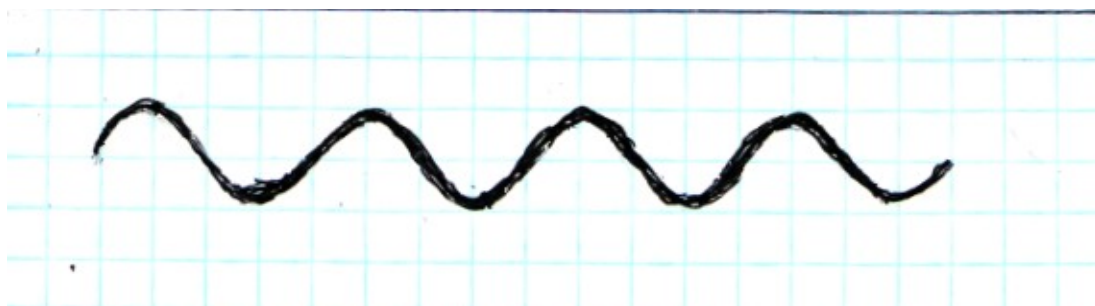

- 5.5.1 What aspect of a sound wave determines its loudness? (1)

5.5.2 The loudness of this wave is doubled. Redraw this wave in your answer book and then (underneath it) draw the new wave that is formed

(3)

5.6 Give TWO uses of ultrasound waves.

(2).

[19]**QUESTION 6**

6.1 State ONE danger of:

6.1.1 ultraviolet rays.

(1)

6.1.2 x-rays.

(1)

6.2 Define a photon.

(2)

6.3 Consider the following light rays:

Light **A** with a frequency of $5,56 \times 10^{14}$ Hz.

Light **B** with a wavelength of 390×10^{-9} m.

USE CALCULATIONS to determine which of the two lights has the highest energy.

(8)

[12]**QUESTION 7**

7.1 Write down the formulae of the reactants and products given in the following word equation and then balance the equation.

ammonium carbonate \longrightarrow carbon dioxide + water + ammonia.

(5)

7.2 Write down the following equation in words:

$O_2 + SO_2 \longrightarrow SO_3$

(3)

[8]**QUESTION 8**

The graph below shows a heating curve of a pure substance.

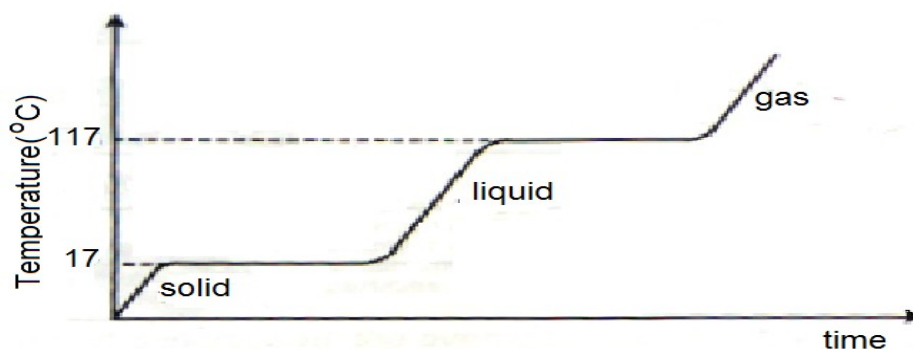

- 8.1 What is the melting point of the substance? (1)
- 8.2 What is the boiling point of the substance? (1)
- 8.3 What happens to the temperature while the substance undergoes a phase change? (1)
- 8.4 How do we know that this substance is not water? (2)
- 8.5 In which phase of matter is the average kinetic energy of the particles the highest? (2)
- [7]**

QUESTION 9

A Grade 10 learner performed an experiment to determine the direction and pattern of the magnetic field around a bar magnet. Based on her results, she drew the following diagram in which the north and south poles of the magnet are correctly labelled.

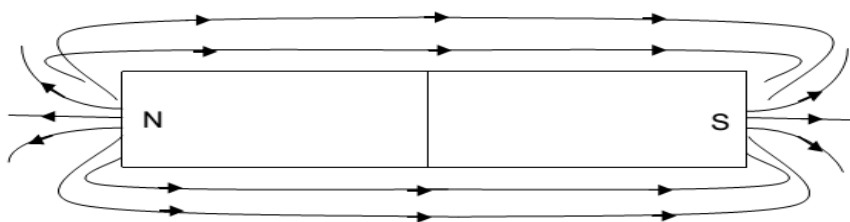

- 9.1.1 Define the term *magnetic field*. (2)
- 9.1.2 Identify THREE mistakes that the learner made in the drawing. (3)
- 9.1.3 Name the device that the learner used to determine the direction of the magnetic field. (1)
- 9.1.4 The learner accidentally dropped the magnet and it broke in the middle into two pieces. Draw a sketch indicating the field and the poles around ONE of the two pieces. (2)
- 9.2 Give a reason why the Earth's magnetic field is important. (2)

[10]

QUESTION 10

A plastic ruler was rubbed with a cloth. After rubbing it had a charge of $+3,2 \times 10^{-15} \text{ C}$.

10.1.1 Did the ruler lose or gain electrons when it became charged? (1)

10.1.2 Give a reason for your answer in QUESTION 10.1.1. (2)

10.1.3 How many electrons did it gain or lose? (3)

Two conducting balls are placed on insulating stands. One has a charge of $-1,6 \times 10^{-9} \text{ C}$ and the other one has a charge of $11,2 \times 10^{-9} \text{ C}$. The two stands are pushed together so that the conducting balls touch and then they are pulled apart.

10.2 Calculate the charge on each of the two balls after they are separated. (3)

In the electric circuit below, the readings on the voltmeters V_1 and V_2 are 3 V and 2 V respectively. The ammeter reading is 1,5 A.

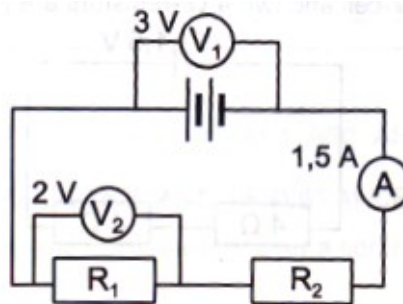

10.3 Define terminal potential difference. (2)

CALCULATE:

10.4.1 The amount of charge that flows through the ammeter in 10 s. (3)

10.4.2 The resistance of the resistor, R_1 (3)

10.4.3 The resistance of the resistor, R_2 (6)

[23]

TOTAL : 150

DATA FOR PHYSICAL SCIENCES GRADE 10**TABLE 1: PHYSICAL CONSTANTS**

NAME	SYMBOL	VALUE
Acceleration due to gravity	G	9.8 m.s ⁻²
Speed of light in a vacuum	C	3.0×10 ⁸ m.s ⁻¹

TABLE 2: FORMULAE**MOTION**

$vf = vi + a\Delta t$	$\Delta x = vi\Delta t + \frac{1}{2}a\Delta t^2$
$vf^2 = vi^2 + 2a\Delta x$	$\Delta x = \left(\frac{vf+vi}{2}\right)\Delta t$

WEIGHT AND MECHANICAL ENERGY

$F_g = mg$	$U = E_p = mgh$
$K = E_k = \frac{1}{2}mv^2$	

WAVES, LIGHT AND SOUND

$v = f\lambda$ or $v = v\lambda$	$f = \frac{1}{T}$
$n_i \sin\theta = n_r \sin\theta_r$	

ELECTRICITY AND MAGNETISM

$I = \frac{Q}{\Delta t}$	$V = \frac{W}{Q}$
$\frac{1}{R_p} = \frac{1}{r_1} + \frac{1}{r_2} + \dots$	$R = \frac{V}{I}$

