



KWAZULU-NATAL PROVINCE

EDUCATION
REPUBLIC OF SOUTH AFRICA



**NATIONAL
SENIOR CERTIFICATE**

GRADE 10

PHYSICAL SCIENCES

COMMON TEST

JUNE 2021

MARKS: 50

TIME : 1 hour

This question paper consists of 7 pages.

INSTRUCTIONS AND INFORMATION

1. Write your name and class (e.g. 10A) in the appropriate spaces on the ANSWER BOOK.
2. This question paper consists of 6 questions. Answer ALL questions in the ANSWER BOOK.
3. Number the answers correctly according to the numbering system used in this question paper.
4. Leave ONE line between two sub-questions, e.g. between QUESTION 2.1 and QUESTION 2.2.
5. You may use a non-programmable calculator.
6. You are advised to use the attached DATA SHEET.
7. Show ALL formulae and substitutions in ALL calculations.
8. Round off your final numerical answers to a minimum of TWO decimal places.
9. Give brief motivations, discussions, etc where required.
10. Write neatly and legibly.

QUESTION 1: MULTIPLE-CHOICE QUESTIONS

Various options are provided as possible answers to the following questions. Each question has only ONE correct answer. Choose the answer and write only the letter (A-D) next to the question numbers (1.1 to 1.4) in the ANSWER BOOK, e.g. 1.5 D

- 1.1 The emf of a battery is the ...
- A energy supplied by the battery per coulomb of charge.
 - B energy supplied by the battery per unit current.
 - C potential difference across the terminals of the battery when delivering current.
 - D force exerted by the battery per unit charge. (2)
- 1.2 Which ONE of the following statements below regarding the AVERAGE velocity and the INSTANTANEOUS velocity of an object is TRUE? They are ...
- A always equal.
 - B never equal.
 - C only equal when the velocity is constant.
 - D only equal when the acceleration is constant. (2)
- 1.3 When a car accelerates at $5 \text{ m}\cdot\text{s}^{-2}$ it means that its...
- A velocity changes by $5 \text{ m}\cdot\text{s}^{-1}$ every second.
 - B velocity changes by $5 \text{ m}\cdot\text{s}^{-1}$ for every 1metre travelled.
 - C acceleration changes by $5 \text{ m}\cdot\text{s}^{-2}$ for every one second.
 - D displacement increases by 5 m for every one second. (2)
- 1.4 A car has a kinetic energy E when it is travelling at a constant velocity. When its velocity is doubled its new kinetic energy will now be ...
- A $\frac{1}{4}E$
 - B $\frac{1}{2}E$
 - C $2E$
 - D $4E$ (2)

[8]

QUESTION 2

Study the circuit diagram below. The readings on ammeters A_1 and A_2 are 3A and 1A respectively. The voltmeters connected across the 6Ω resistor and the resistor R both read 6V.

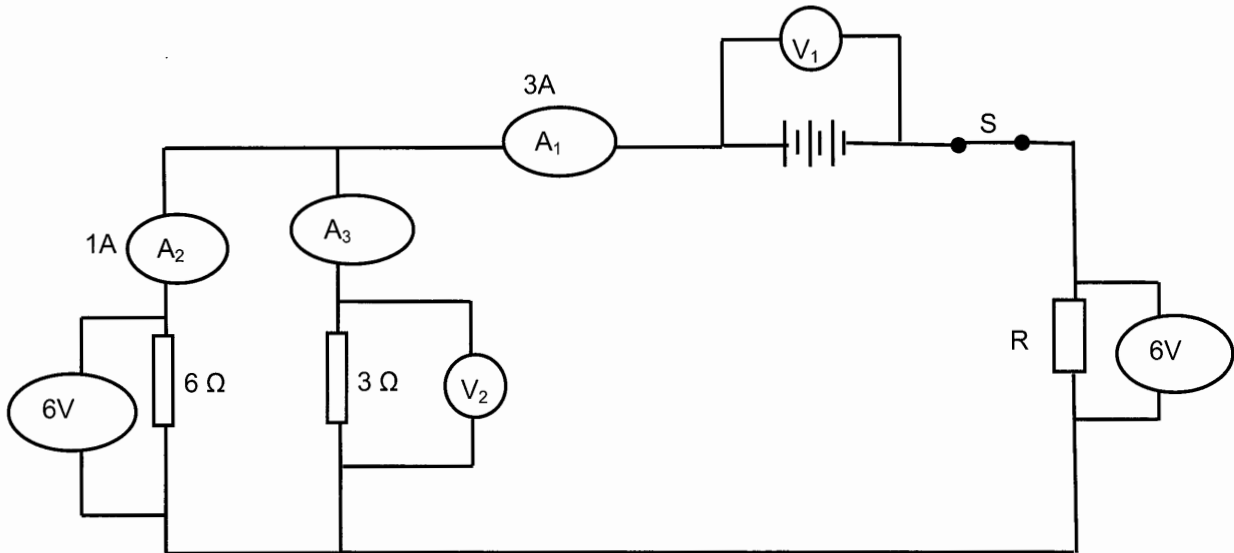

- 2.1 Define the term *current strength*. (1)
- 2.2 What is the reading on:
- 2.2.1 Ammeter A_3 ? (1)
- 2.2.2 Voltmeter V_2 ? (1)
- 2.2.3 Voltmeter V_1 ? (1)
- 2.3 Calculate the effective resistance for the resistors connected in parallel. (3)
- 2.4 If the total resistance of the circuit is 4Ω , determine the resistance of resistor R. (2)
- 2.5 Calculate the quantity of charge that flows through resistor R in 2 minutes. (3)
- 2.6 Determine how much electrical work will be done by the battery in 2 minutes. (3)
- [15]**

QUESTION 3

A jogger starts at position A and runs 70m due west to position B. He then turns around and runs 85m due east to position C.

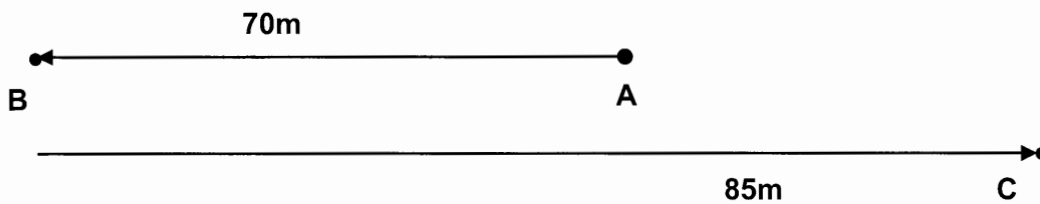

- 3.1 Define a *vector*. (1)
- 3.2 Determine his final displacement when using:
- 3.2.1 Position A as a reference point. (1)
- 3.2.2 Position B as a reference point. (1)
- 3.3 Determine the total distance travelled by the jogger. (1)

[4]**QUESTION 4**

The velocity versus time graph below illustrates the motion of an object that is initially travelling in an EASTERLY direction. Its initial position at time $t=0$ is taken as 0 m.

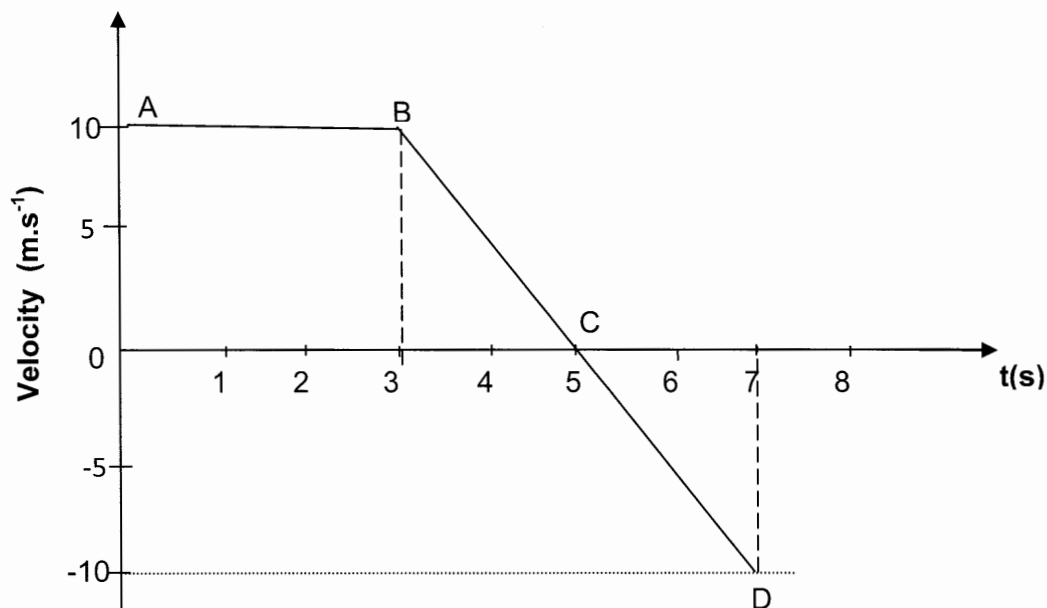

- 4.1 Describe the motion of the object during segment AB. (1)
- 4.2 In which direction is the object moving during segment BC? (EAST or WEST) (1)
- 4.3 Calculate the magnitude and direction of the acceleration during segment BD. (3)
- 4.4 Calculate the total distance travelled by the object from A to C. (2)
- 4.5 Calculate the object's average speed between A and C. (2)
- 4.6 As the object moves from B to C, describe the motion of the object from C to D. (2)

[11]

QUESTION 5

A motorist travelling due south at $30 \text{ m}\cdot\text{s}^{-1}$ applies brakes uniformly and takes 4 s to bring the car to a stop.

- 5.1 Define *acceleration*. (1)
- 5.2 Calculate the distance covered by the car when the brakes are applied. (3)
- 5.3 Determine the acceleration of the car when the brakes are applied. (3)

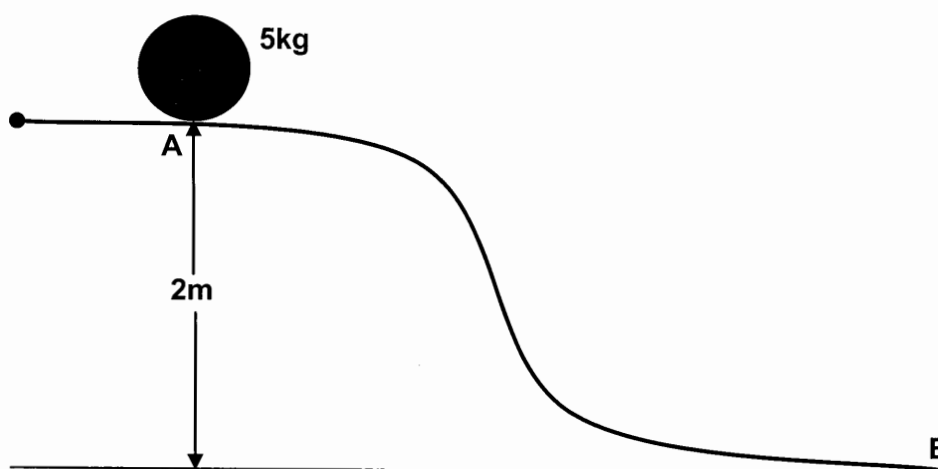
[7]**QUESTION 6**

A 5kg ball starts from rest at position A that is at a vertical height of 2 m and rolls freely down a slope to position B. Ignore the effects of friction.

- 6.1 State the *law of conservation of mechanical energy* in words. (1)
- 6.2 Using the law of conservation of mechanical energy only, calculate the speed of the ball when it reaches position B. (4)

[5]**TOTAL : 50**

**DATA FOR PHYSICAL SCIENCES GRADE 10
JUNE 2021**

TABLE 1: PHYSICAL CONSTANTS

NAME	SYMBOL	VALUE
Electron charge	Q_e	$-1,6 \times 10^{-19} \text{ C}$
Acceleration due to gravity	g	$9,8 \text{ m}\cdot\text{s}^{-2}$

TABLE 2: FORMULAE**WAVES, SOUND AND LIGHT**

$v = f\lambda$ or $c = f\lambda$	$T = \frac{1}{f}$	$E = hf$
----------------------------------	-------------------	----------

ELECTROSTATICS

$n = \frac{Q}{Q_e}$	$Q = \frac{Q_1 + Q_2}{2}$
---------------------	---------------------------

ELECTRIC CIRCUIT

$Q = I \Delta t$	$\frac{1}{R_p} = \frac{1}{R_1} + \frac{1}{R_2} + \dots$
$R_s = R_1 + R_2 + \dots$	$V = \frac{W}{Q}$

MOTION/BEWEGING

$v_f = v_i + a \Delta t$	$\Delta x = v_i \Delta t + \frac{1}{2} a \Delta t^2$ or/of $\Delta y = v_i \Delta t + \frac{1}{2} a \Delta t^2$
$v_f^2 = v_i^2 + 2a\Delta x$ or/of $v_f^2 = v_i^2 + 2a\Delta y$	$\Delta x = \left(\frac{v_i + v_f}{2} \right) \Delta t$ or/of $\Delta y = \left(\frac{v_i + v_f}{2} \right) \Delta t$

ENERGY

$E_p = mgh$ or $U = mgh$	$E_k = \frac{1}{2} mv^2$ or $K = \frac{1}{2} mv^2$
--------------------------	--

