

**PROVINCIAL EXAMINATION**  
**NOVEMBER 2022**  
**GRADE 10**

**PHYSICAL SCIENCES (PHYSICS)**  
**(PAPER 1)**

**TIME: 2 hours**

**MARKS: 100**

**11 pages and 2 formula sheets**

### **INSTRUCTIONS AND INFORMATION**

1. Write your name in the appropriate space on the ANSWER BOOK.
2. This question paper consists of 8 questions. Answer ALL the questions.
3. Start each question on a NEW page in the ANSWER BOOK.
4. Number the answers correctly according to the numbering system used in this question paper.
5. You may use a non-programmable calculator.
6. You may use appropriate mathematical instruments.
7. USE the DATA SHEETS that are attached.
8. Show ALL formulae and substitutions in ALL calculations.
9. Round off your final numerical answers to a minimum of TWO decimal places.
10. Write neatly and legibly.

### QUESTION 1: MULTIPLE-CHOICE QUESTIONS

Four options are provided as possible answers to the following questions. Each question has only ONE correct answer. Write only the letter (A – D) next to the question numbers (1.1 to 1.8) in the ANSWER BOOK, e.g. 1.9 E.

1.1 Which of the following physical quantities is not a vector?

- A Distance
- B Force
- C Velocity
- D Acceleration

(2)

1.2 In the equation  $\Delta x = v_i \Delta t + \frac{1}{2} a \Delta t^2$ , the part  $v_i \Delta t$  represents the ...

- A time.
- B velocity.
- C acceleration.
- D displacement.

(2)

1.3 Which of the following is obtained by calculating gradient of displacement versus time graph?

- A Time
- B Velocity
- C Acceleration
- D Displacement

(2)

1.4 In the diagram below, a pendulum bob of mass  $m$  is released from point **A** and swings past points **B**, **C** and **D**. Ignore all effects of air resistance.

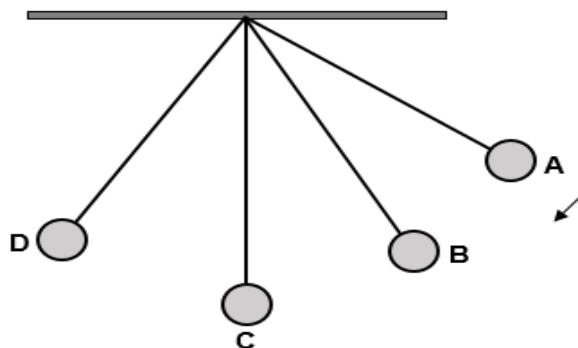

In which of the following positions will the value of the gravitational potential energy of the pendulum bob be the smallest?

- A A
- B B
- C C
- D D

(2)

1.5 The number of sound vibrations per second is the:

- A Period
- B Frequency
- C Amplitude
- D Wavelength

(2)

1.6 Two identical spheres, **A** and **B**, on insulated stands, carry different charges. The spheres are brought into contact and separated again.

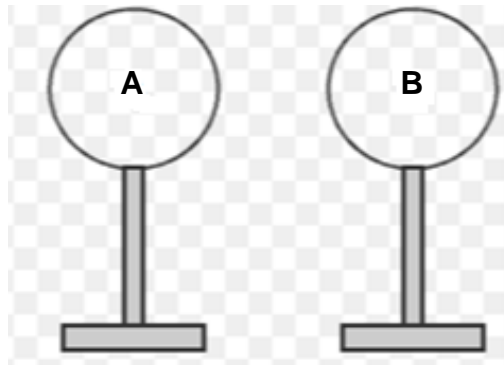

If the charge on sphere **A** AFTER the separation is  $q$ , the charge on sphere **B** after the separation is ...

- A  $-q$ .
- B  $q$ .
- C zero.
- D  $2q$ .

(2)

1.7 Consider the circuit diagram below:

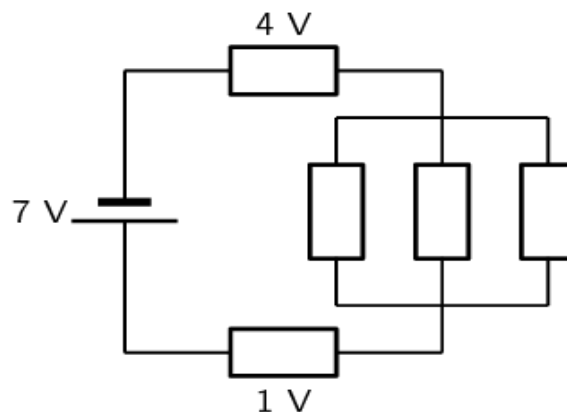

What is the voltage across the parallel resistors?

- A 5V
- B 7V
- C 2V
- D 4V

(2)

- 1.8 Which of the following statements best describes resistance in parallel?
- A Adding more resistors in parallel decreases the total current of the circuit
  - B Adding more resistors in parallel decreases the effective resistance of the circuit
  - C Removing a resistor in parallel increases the total current of the circuit
  - D Removing a resistor in parallel decreases the effective resistance of the circuit

(2)  
[16]

**QUESTION 2 (Start on a new page.)**

- 2.1 Define the term *vector*. (2)
- 2.2 Peter stands at the front door of his house. Avogadro Street is 25 m away from the front door. Peter walks to Avogadro Street and back to the front door of his house.

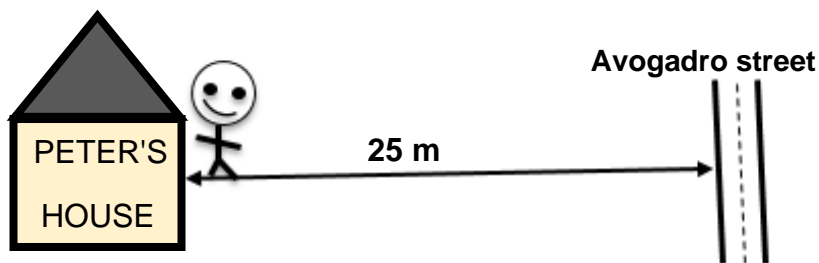

- 2.2.1 What is the distance that Peter has walked? (2)
- 2.2.2 Write Peter's final displacement? (2)
- 2.2.3 Is displacement a vector or a scalar? Give a reason for your answer. (2)

[8]

**QUESTION 3 (Start on a new page.)**

Car **A** driving at  $135 \text{ km}\cdot\text{h}^{-1}$  approaches a stationary car **B**. The driver of car **B** noticed that car **A** is approaching him at a very high speed. The driver of car **B** reacted suddenly by accelerating his car from rest at  $1,5 \text{ m}\cdot\text{s}^{-2}$  for  $11,5 \text{ s}$ . After  $11,5 \text{ s}$  car **B** continued driving with a



- 3.1 Convert  $135 \text{ km}\cdot\text{h}^{-1}$  to  $\text{m}\cdot\text{s}^{-1}$ . (2)
- 3.2 Determine the velocity of car **B** while trying to avoid car **A**. (4)
- 3.3 How far has car **B** driven after  $11,5$  seconds? (4)
- 3.4 The driver of car **A** suddenly hit the brakes and managed to stop after  $40 \text{ m}$ . What acceleration does car **A** experience to come to a standstill after  $4$  seconds? (4)

**[14]**

**QUESTION 4 (Start on a new page.)**

Study the velocity versus time graph below for the motion of a car travelling east.

**Velocity vs time graph**

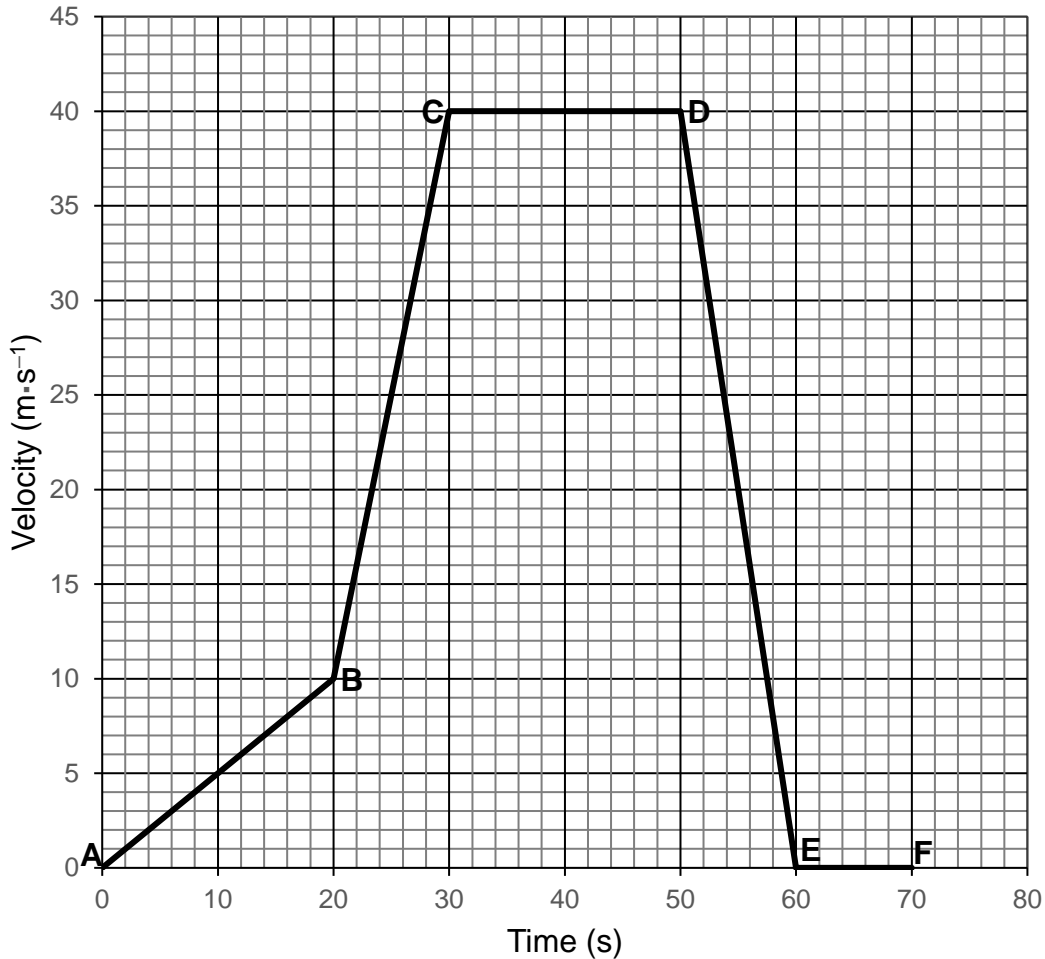

- 4.1 Define the term *acceleration*. (2)
- 4.2 Use the graph to describe the motion of the car in the following sections:
- 4.2.1 **AB** (2)
- 4.2.2 **CD** (2)
- 4.2.3 **EF** (2)
- 4.3 Calculate the acceleration of the car between **D** and **E**. (4)
- 4.4 In which section, **AB** or **BC**, is the acceleration of the car the greatest? Give a reason for your answer. (2)

[14]

**QUESTION 5 (Start on a new page.)**

A rollercoaster cart of mass 2 kg is released from rest at point **A**, 30 metres above the ground. The cart moves along a frictionless surface **ABC** as shown below.

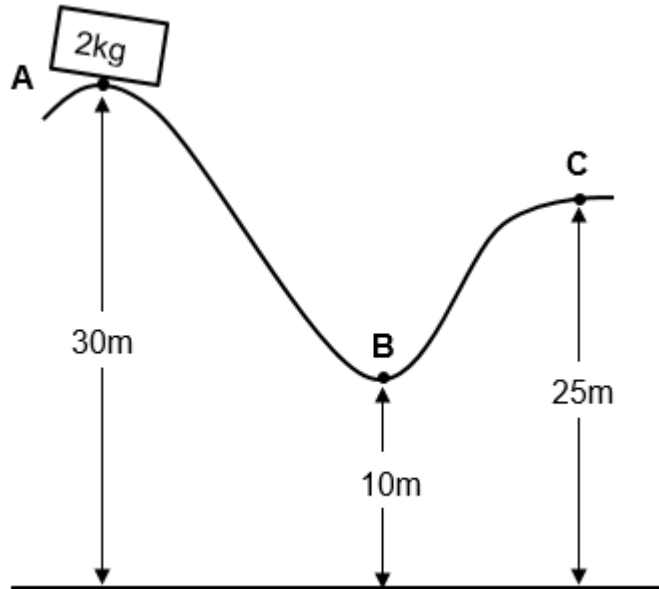

- 5.1 Define the term *gravitational potential energy*. (2)
- 5.2 Prove with calculations that the mechanical energy of the cart at point **A** is 588 J. (3)
- 5.3 State the *law of conservation of mechanical energy* in words. (2)
- 5.4 Calculate the velocity of the cart when it is at point **B**. (4)
- 5.5 How will the mechanical energy of the cart at point **C** compare with the mechanical energy of the cart at point **B**? Write only GREATER THAN, LESS THAN or EQUAL TO. Give a reason for your answer. (2)

**[13]**

**QUESTION 6 (Start on a new page.)**

The diagram represents the pattern of waves with frequency 30 Hz, moving from the left to right.

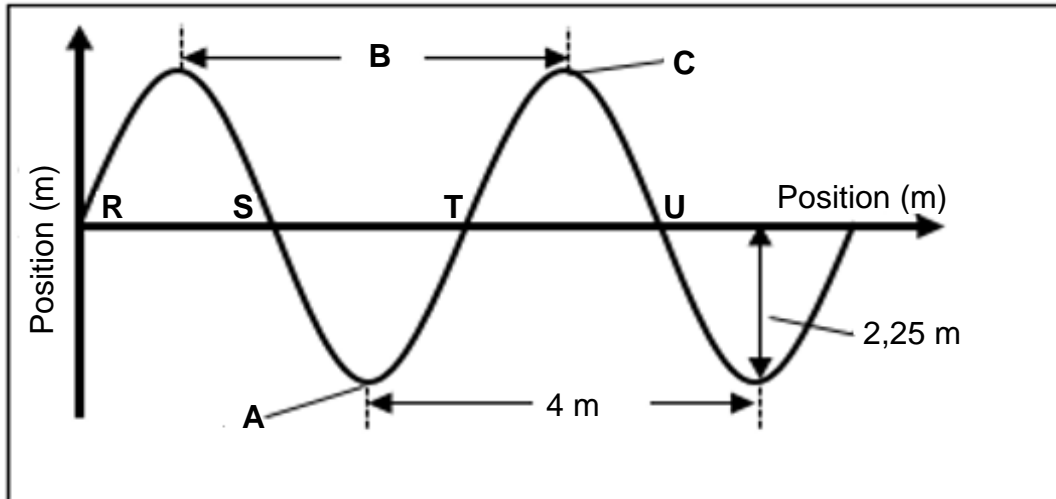

- 6.1 Define the term *transverse wave*. (2)
- 6.2 Label points **A**, **B** and **C**. (3)
- 6.3 How much time has lapsed while the wave moved from **R** to **T**? (2)
- 6.4 Are points **R** and **S** on the wave in phase? Explain your answer. (2)
- 6.5 Calculate the speed of the wave. (3)

**[12]**

**QUESTION 7 (Start on a new page.)**

Two identical insulated spheres, **A** and **B**, suspended by a light inextensible string from a ceiling, are held a distance apart, as shown below.

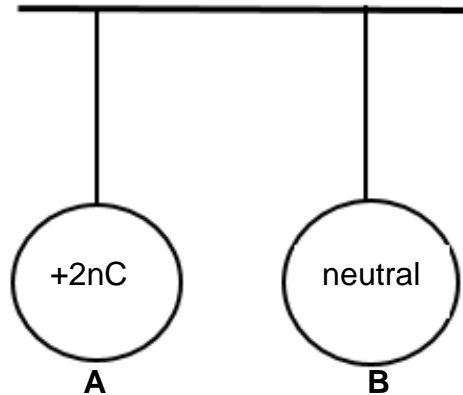

Sphere **A** carries a charge of  $+2nC$ , while sphere **B** is neutral.

7.1 Explain what is meant by *neutral charge*. (2)

Sphere **A** is brought near the neutral sphere **B** and the spheres are allowed to touch each other. Immediately after touching, sphere **B** moves away from sphere **A**. Sphere **B** now has an excess of 20 electrons.

7.2 State the *principle of conservation of charge* in words. (2)

7.3 Briefly explain how the neutral sphere **B** is attracted to sphere **A**. (2)

7.4 Calculate the magnitude of the charge of sphere **B**. (3)

7.5 Calculate the charge on each sphere after they have separated. (3)

**[12]**

**QUESTION 8 (Start on a new page.)**

In the circuit diagram below, each cell has a voltage of 1,5 V. Use the diagram to answer the questions that follow.

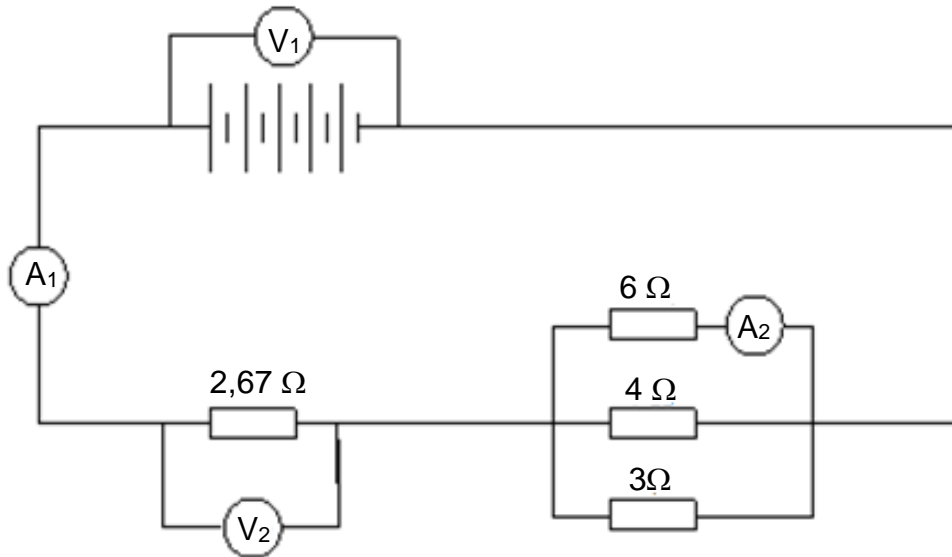

- 8.1 What is the reading on  $V_1$ ? (1)
- 8.2 Calculate the following:
- 8.2.1 Total resistance of the circuit (3)
- 8.2.2 Reading on  $A_1$  (2)
- 8.2.3 The reading on  $V_2$  (2)
- 8.3 Determine the magnitude of the charge that flows through  $A_1$  in 6 minutes. (3)
- [11]

**TOTAL: 100**

**END**

DATA FOR PHYSICAL SCIENCES GRADE 10  
PAPER 1 (PHYSICS)

GEGEWENS VIR FISIESTE WETENSKAPPE GRAAD 10  
VRAESTEL 1 (FISIKA)

TABLE 1: PHYSICAL CONSTANTS/TABEL 1: FISIESTE KONSTANTES

NAME/NAAM	SYMBOL/SIMBOOL	VALUE/WAARDE
Acceleration due to gravity <i>Swaartekragversnelling</i>	g	9,8 m·s <sup>-2</sup>
Speed of light in a vacuum <i>Spoed van lig in 'n vakuum</i>	c	3,0 x 10 <sup>8</sup> m·s <sup>-1</sup>
Planck's constant <i>Planck se konstante</i>	h	6,63 x 10 <sup>-34</sup> J·s
Charge on electron <i>Lading op elektron</i>	e	-1,6 x 10 <sup>-19</sup> C
Electron mass <i>Elektronmassa</i>	m <sub>e</sub>	9,11 x 10 <sup>-31</sup> kg

TABLE 2: FORMULAE/TABEL 2: FORMULES

MOTION/BEWEGING

$v_f = v_i + a\Delta t$	$\Delta x = v_i\Delta t + \frac{1}{2}a\Delta t^2$
$v_f^2 = v_i^2 + 2a\Delta x$	$\Delta x = \left(\frac{v_f + v_i}{2}\right)\Delta t$

WORK, ENERGY AND POWER/ARBEID, ENERGIE EN DRYWING

$U = mgh$ or/of $E_p = mgh$	$K = \frac{1}{2}mv^2$ or/of $E_k = \frac{1}{2}mv^2$
$E_M = E_k + E_p$ or/of $E_M = K + U$	

WAVES, SOUND AND LIGHT/GOLWE, KLANK EN LIG

$v = f\lambda$	$T = \frac{1}{f}$
$E = hf$ or/of $E = h\frac{c}{\lambda}$	

**ELECTROSTATICS/ELEKTROSTATIKA**

$n = \frac{Q}{e}$	$Q = \frac{Q_1 + Q_2}{2}$
-------------------	---------------------------

**ELECTRIC CIRCUITS/ELEKTRIESE STROOMBANE**

$Q = I \Delta t$	$\frac{1}{R_p} = \frac{1}{R_1} + \frac{1}{R_2} + \dots$
$R_s = R_1 + R_2 + \dots$	$V = \frac{W}{Q}$