



Province of the
EASTERN CAPE
EDUCATION

**NATIONAL
SENIOR CERTIFICATE**

GRADE/GRAAD 11

NOVEMBER 2015

**PHYSICAL SCIENCES P1/
FISIESE WETENSKAPPE V1
MEMORANDUM**

MARKS/PUNTE: 150

This memorandum consists of 10 pages./
Hierdie memorandum bestaan uit 10 bladsye.

QUESTION/VRAAG 1

- 1.1 A ✓✓
 1.2 A ✓✓
 1.3 A ✓✓
 1.4 D ✓✓
 1.5 B ✓✓
 1.6 B ✓✓
 1.7 D ✓✓
 1.8 D ✓✓
 1.9 A ✓✓
 1.10 C ✓✓

[20]**QUESTION/VRAAG 2**

- 2.1 The resultant of the forces is zero. ✓
 Die resultant van die kragte is nul. ✓

(1)

2.2

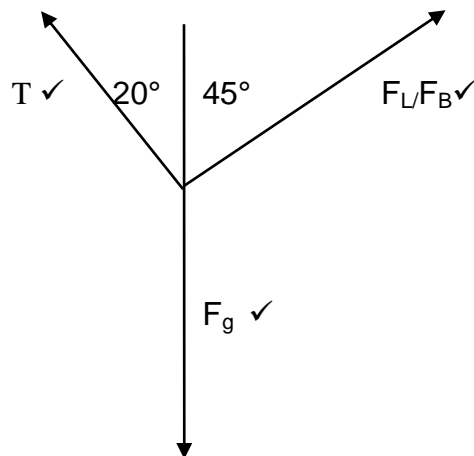

ACCEPTED LABELS/AANVAARDE BYSKRIFTE	
F_g	F_w/W /Weight/mg/gravitational force/force due to gravity F_w/W /gewig/mg/gravitasiekrag
T	F_T /Tension/Tension in rope F_T /Spanning/Spanning in tou
F_L F_B	F_{legs} /Force of legs on wall F_{bene} /Krag van bene op muur

(3)

- 2.3 $F_g = mg = (50)(9,8) = 490 \text{ N} \checkmark$
 SCALE/SKAAL $10 \text{ mm} = 50 \text{ N}$
 $F_g = 490 \text{ N} = 98 \text{ mm}$ (Accept/Aanvaar $97 - 99 \text{ mm}$)

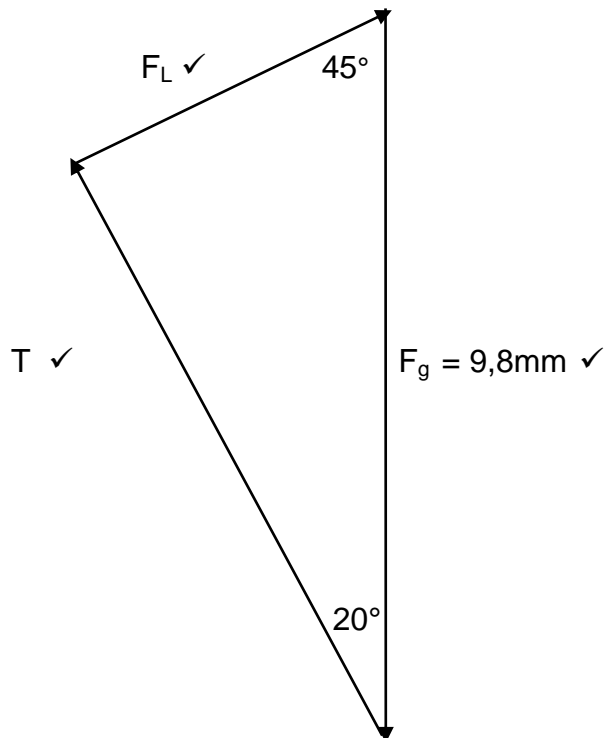

$T = 76,5 \times 5 = 382,5 \text{ N} \checkmark$ (Accept/Aanvaar $76,4 - 76,6 \text{ mm}$)
 $F_L = 37,0 \times 5 = 185 \text{ N} \checkmark$ (Accept/Aanvaar $184,5 - 186,5 \text{ mm}$) (8)

NOTES/AANTEKENINGE

- Mark awarded for correct label and direction./
- Punt toegeken vir korrekte benoeming en pyltjie.
- ANY TWO angles indicated./✓✓
- ENIGE TWEE hoeke aangedui. ✓✓

OR/OF

CALCULATIONS instead of CONSTRUCTION/
 BEREKENINGE in plaas van KONSTRUKSIES

max/maks $\frac{5}{8}$

$$\frac{F_g}{\sin 115^\circ} = \frac{F_T}{\sin 45^\circ} \Rightarrow F_T = \frac{490 \sin 45^\circ}{\sin 115^\circ} \checkmark = 382,50 \text{ N} \checkmark$$

$$\frac{F_r}{\sin 20^\circ} = \frac{F_g}{\sin 115^\circ} \Rightarrow F_R = \frac{490 \sin 20^\circ}{\sin 115^\circ} \checkmark = 184,91 \text{ N} \checkmark$$

[12]

QUESTION/VRAAG 3

3.1 $f_s = F_{g\parallel} = mg \sin \theta = (60)(9,8) \sin 30^\circ \checkmark = 294 \text{ N} \checkmark$
 Any one/Enige een \checkmark (3)

3.2 $\mu_s = \tan \theta \checkmark = \tan 30^\circ \checkmark = 0,58 \checkmark$
 OR/OF
 $f_s = \mu_s F_N = \mu_s F_{g\perp} = \mu_s mg \cos \theta \checkmark$
 $294 = \mu_s (60)(9,8) \cos 30^\circ \checkmark$
 $\mu_s = 0,58 \checkmark$ (3)

3.3 3.3.1 REMAINS THE SAME/BLY DIESELFDE \checkmark (1)

3.3.2 DECREASES/NEEM AF \checkmark

$F_{g\perp}$ will decrease, \checkmark therefore F_N will decrease/ $f_k \propto F_N \checkmark$
 $F_{g\perp}$ sal afneem, \checkmark dus sal F_N afneem \checkmark / $f_k \propto F_N \checkmark$ (3)

[10]

QUESTION/VRAAG 4

4.1 When a resultant/net force acts on an object, the object accelerates in the direction of the force. This acceleration is directly proportional to the force \checkmark and inversely proportional to the mass of the object. \checkmark

Indien 'n resulterende/netto krag op 'n voorwerp inwerk, sal die voorwerp in die rigting van die krag versnel. Hierdie versnelling is direk eweredig aan die (resulterende/netto) krag \checkmark en omgekeerd eweredig aan die massa van die voorwerp. \checkmark

OR/OF

The net force acting on an object is equal to the rate of change of momentum $\checkmark\checkmark$ of the object (in the direction of the force). (2 or 0)

Die netto krag wat op 'n voorwerp inwerk is gelyk aan die tempo van verandering in momentum $\checkmark\checkmark$ van die voorwerp (in die rigting van die krag). (2 of 0) (2)

4.2

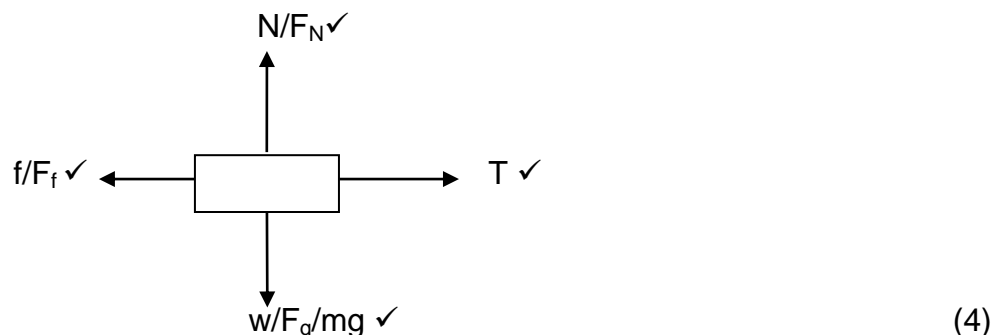
**NOTES/AANTEKENINGE**

- Mark awarded for label and arrow./Punt toegeken vir benoeming en pyltjie.
- Any other additional force(s)/Enige ander addisionele krag(te). Max/Maks $\frac{3}{4}$
- If force(s) do not make contact with body/Indien krag(te) nie met die voorwerp kontak maak nie. Max/Maks $\frac{3}{4}$

4.3 4.3.1 **OPTION/OPSIE 1**

For the 6kg block./Vir 6kg blokkie:

$$F_{net} = ma \checkmark$$

$$T + (-f_f) = ma$$

$$T - 11,76 \checkmark = 6a \dots\dots\dots(1)$$

For the 2kg block./Vir 2kg blokkie:

✓ For either/vir of/6a or/of 2a

$$F_{net} = ma$$

$$2 + w + (-T) = ma$$

$$2 + (2 \times 9,8) - T \checkmark = 2a$$

$$T = 21,6 - 2a \dots\dots\dots(2)$$

Substitute (2) into (1)/Stel (2) in (1):

$$21,6 - 2a - 11,76 = 6a$$

$$a = 1,23 \text{ m.s}^{-2} \checkmark$$

OPTION/OPSIE 2:

$$F_{net} = ma \checkmark$$

$$2 + w + (-F_f) \checkmark = ma$$

$$2 + (2 \times 9,8) - F_f \checkmark = 8a \checkmark$$

$$2 + (2 \times 9,8) - 11,76 = 8a$$

$$a = 1,23 \text{ m.s}^{-2} \checkmark \quad (5)$$

4.3.2 **POSITIVE MARKING from QUESTION 4.3.1**
POSITIEWE NASIEN van VRAAG 4.3.1

$$T = 21,6 - 2a$$

$$= 21,6 - 2(1,23) \checkmark$$

$$= 19,14 \text{ N} \checkmark$$

OR/OF

$$T - 11,76 = 6a$$

$$T = 11,76 + 6(1,23) \checkmark$$

$$= 19,14 \text{ N} \checkmark \quad (2)$$

4.4 INCREASES/TOENEEM ✓ (1)

[14]

QUESTION/VRAAG 5

5.1 BACKWARDS/AGTERTOEF ✓ (1)

5.2 An object continues in a state of rest or uniform velocity, unless it is acted upon by an external unbalanced force (resultant force). ✓

'n Voorwerp sal in 'n toestand van rus bly of teen 'n konstante snelheid bly voortbeweeg, tensy 'n eksterne ongebalanseerde (resulterende krag) daarop inwerk. ✓

OR/OF

The tendency of an object to maintain its state of rest or constant motion in a straight line. ✓

Die weerstand van 'n voorwerp wat enige verandering in sy toestand rus of beweging teenstaan. ✓ (2)

5.3 5.3.1 EQUALS/GELYK ✓ (1)

5.3.2 Kay will have a greater acceleration, ✓ because her mass is smaller. ✓
Kay sal 'n groter versnelling het, ✓ want haar massa is kleiner. ✓ (2)
[6]

QUESTION/VRAAG 6

6.1 Action: Force of seat on astronaut (upwards) ✓
 Reaction: Force of astronaut on seat (downwards) ✓

Aksie: Krag van sitplek op ruimtevaarder (opwaarts) ✓
Reaksie: Krag van ruimtevaarder op sitplek (afwaarts) ✓ (2)

6.2 $F_{RES} = \frac{m \Delta v}{\Delta t} \checkmark = \frac{(2,6 \times 10^6)(160 - 0)}{400} \checkmark = 1,04 \times 10^6 \text{ N} \checkmark$ upwards/opwaarts ✓

Mark direction independently/Merk rigting onafhanklik (5)

QUESTION/VRAAG 7

7.1 $F = \frac{G m_1 m_2}{r^2} \checkmark$
 $= \frac{(6,67 \times 10^{-11})(7,35 \times 10^{22})(6 \times 10^{24})}{(3 \times 10^9)^2} \checkmark$
 $= 1,99 \times 10^{18} \text{ N} \checkmark$ (4)

7.2 NEWTON'S LAW OF GRAVITATION/NEWTON se GRAVITASIEWET. ✓ (1)

7.3 The distance between the earth and the moon changes due to the elliptical orbit. ✓
Die afstand tussen die aarde en die maan verander as gevolg van elliptiese omwenteling. ✓

OR/OF

$F \propto 1/r^2 \checkmark$ (1)

7.4 $F_{EM(new)} = \frac{GM_E 1/4 M_M}{(2r)^2} \checkmark = F_{EM} (1/4)(1/4) \checkmark = 1/16 F_{EM} \checkmark$

OR/OF

$F_{EM(new)} = 1/16 (1,99 \times 10^{18}) \checkmark$

OR/OF

$F_{EM(new)} = 1,24 \times 10^{17} \text{ N} \checkmark$ (1,24375 × 10¹⁷ N) (3)
[9]

QUESTION/VRAAG 8

8.1 Angle of incidence/ θ_i / $\sin \theta_i$ ✓
 Invalshoek/ θ_i / $\sin \theta_i$ ✓ (1)

8.2 Type of block used/Temperature of the surroundings/Source of light/Surface on which block is placed. ✓.
 Tipe blok gebruik/Temperatuur van die omgewing/Bron van die lig/Oppervlak waarop blok geplaas word. ✓ (1)

8.3 Snell's law has been verified:
 * The graph is a straight line through the origin, because $\sin \theta_i \propto \sin \theta_r$. ✓
 * Gradient = $\frac{\sin \theta_i}{\sin \theta_r} = \text{constant}$ ✓
 Snell se wet is bewys:
 • Die grafiek vorm 'n reguitlyn deur die oorsprong, omdat $\sin \theta_i \propto \sin \theta_r$. ✓
 • Gradiënt = $\frac{\sin \theta_i}{\sin \theta_r} = \text{konstante}$ ✓ (2)

8.4 Gradient/Gradiënt = $n = \frac{\Delta \sin \theta_i}{\Delta \sin r} = \frac{0,77 - 0}{0,51 - 0} = 1,51$ ✓ (4)
[8]

QUESTION/VRAAG 9

9.1 $n \sin \theta_i = n \sin \theta_r$ ✓
 $2,42 \sin \theta_i = 1 \sin 90^\circ$ ✓
 $\theta_i = \sin^{-1} 2,42$
 $= 24,2^\circ$ ✓ (4)

9.2

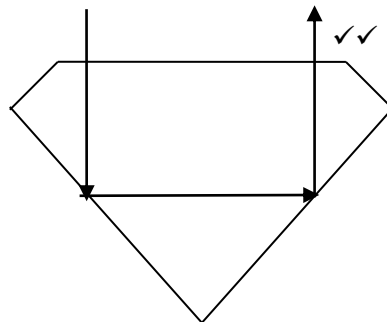

No arrows: max $\frac{1}{2}$
 Geen pyltjies: maks

(2)

9.3 Total internal reflection ✓/Totale interne weerkaatsing ✓ (1)

9.4 Light moves from medium of higher optical density to medium of lower optical density. ✓
 Angle of incidence must be larger than critical angle. ✓
 Lig beweeg van medium van hoër optiese digtheid na medium met laer optiese digtheid. ✓
 Invalshoek moet groter wees as kritiese hoek. ✓ (2)

9.5 Endoscope/Endoskoop ✓ (1)
[10]

QUESTION/VRAAG 10

- 10.1 Light consisting of only one wavelength. ✓
Lig wat uit net een golflengte bestaan. ✓

(1)

10.2

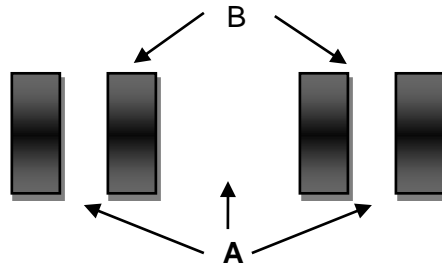

Broader Central band
Breër sentraleband ✓

Alternative light (bright) and dark bands.
Afwisselende helder (lig) en donker bande ✓

A: central band and bright (light) bands = CONSTRUCTIVE INTERFERENCES ✓
sentraleband en helder (lig)bande = KONSTRUKTIEWE INTERFERENSIE/STEURINGE ✓

B: dark bands = DESTRUCTIVE INTERFERENCES ✓
donkerbande = DESTRUKTIEWE INTERFERENSIE/STEURINGE ✓ (4)

- 10.3 10.3.1 INCREASES/NEEM TOE ✓

(1)

- 10.3.2 INCREASES/NEEM TOE ✓



The narrower the opening, the greater the degree of diffraction. ✓

Hoe smaller die opening, hoe groter die mate van diffraksie. ✓

OR/OF

Degree of diffraction $\propto \frac{1}{\text{Width of opening}}$ ✓

Mate van diffraksie $\propto \frac{1}{\text{Wydte van opening}}$ ✓

(2)
[8]**QUESTION/VRAAG 11**

- 11.1 Force experienced per unit charge at a point in the field. ✓✓
Krag ondervind per eenheidslading by 'n punt in die veld. ✓✓

OR/OF

It is the force experienced by a unit positive charge placed at that point. ✓✓
Dit is die krag wat deur 'n eenheids positiewe lading geplaas by daardie punt ondervind word. ✓✓

(2)

11.2

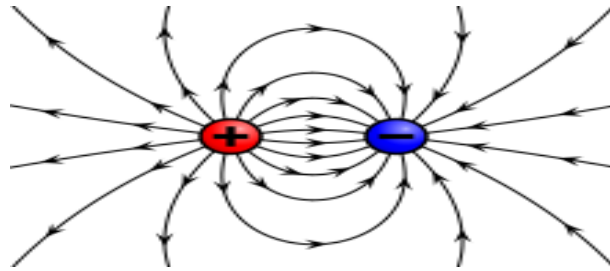

CRITERIA FOR SKETCH/KRITERIA VIR SKETS	MARKS/PUNTE
Correct shape / Korrekte vorm	✓
Direction from positive to negative <i>Rigting van positief na negatief</i>	✓
Fieldlines start on sphere and do not cross <i>Veldlyne begin op elke sfeer en kruis nie</i>	✓

(3)

11.3

$$E_p = \frac{kQ}{r^2} = \frac{(9 \times 10^9)(4 \times 10^{-9})}{(0,10)^2} \checkmark = 3\,600 \text{ N.C}^{-1} \text{ to the right/na regs}$$
 Any ONE / Enige EEN

$$E_Q = \frac{kQ}{r^2} = \frac{(9 \times 10^9)(2 \times 10^{-9})}{(0,02)^2} \checkmark = 45\,000 \text{ N.C}^{-1} \text{ to the left/na links}$$

$$E_{net} = 3\,600 - 45\,000 = 41\,400 \text{ N.C}^{-1} \checkmark \text{ to the left/na links} \checkmark \quad (7)$$

11.4 **POSITIVE MARKING FROM QUESTION 11.3**
POSITIEWE NASIEN VAN VRAAG 11.3

$$E = \frac{F}{Q} \checkmark$$

$$41\,400 = \frac{F}{1,6 \times 10^{-19}} \checkmark$$

$$F = 6,62 \times 10^{-15} \text{ N} \checkmark \quad (3)$$

[15]

QUESTION/VRAAG 12

12.1

12.1.1

$$\Phi = BA \cos \theta \checkmark$$

$$= (0,6) \pi r^2 \cos \theta$$

$$= (0,6)(\pi \times 0,06^2) \checkmark \cos 0^\circ \checkmark$$

$$= (0,6)(0,01)$$

$$= 6,79 \times 10^{-3} \text{ Wb} \checkmark$$

(4)

12.1.2

POSITIVE MARKING FROM QUESTION 12.1.1
POSITIEWE NASIEN VAN VRAAG 12.1.1

$$\varepsilon = \frac{-N \Delta \Phi}{\Delta t} \checkmark$$

$$= \frac{(-1)(0 - 6,79 \times 10^{-3})}{0,04} \checkmark$$

$$= 0,17 \text{ V} \checkmark$$

(4)

- 1.2.2 12.2.1 DECREASES/NEEM AF ✓ (1)
- 12.2.2 INCREASES/NEEM TOE ✓ (1)
- [10]

QUESTION/VRAAG 13

- 13.1 13.1.1 $P = I^2 R$ ✓
 $0,5 = I^2 8$ ✓
 $I = 0,25 \text{ A}$ ✓
- $\frac{1}{R_p} = \frac{1}{r_1} + \frac{1}{r_2}$ ✓ = $\frac{1}{6} + \frac{1}{(6+6)}$ ✓ = $\frac{3}{12}$ $\therefore R_p = 4 \Omega$
- $R_T = 8 + 4$ ✓ = 12Ω
- $V_T = I R_T = (0,25)(12) = 3 \text{ V}$ ✓ (8)
- 13.1.2 $V_p = I R$ ✓ = $(0,25)(4)$ ✓ = 1 V
 $I = \frac{V_p}{R} = \frac{1}{6}$ ✓ = $0,17 \text{ A}$ ✓ (4)

- 13.2 13.2.1 $P = \frac{V^2}{R}$ ✓
 $750 \text{ ✓} = \frac{240^2}{R}$ ✓
 $R = 76,80 \Omega$ ✓

OR/OF

$P = VI$
 $750 \text{ ✓} = 240 I$ ✓
 $I = 3,13 \text{ A}$

$R = \frac{V}{I}$
 $= \frac{240}{3,13}$
 $= 76,80 \Omega$ ✓ (4)

- 13.2.2 $E = P \times t = 750 \times 6$ ✓ = $4\,500 \text{ Wh} = 4,5 \text{ kWh}$
 Cost/Koste = $4,5 \times 1,14$ ✓ = $R\,5,13$ ✓

OR/OF

Cost/Koste = $(0,75)(6)$ ✓ $(1,14)$ ✓ = $R\,5,13$ ✓ (3)

[19]

TOTAL/TOTAAL: 150