



**NATIONAL  
SENIOR CERTIFICATE**

**GRADE 11**

**NOVEMBER 2016**

**PHYSICAL SCIENCES P1/  
FISIESE WETENSKAPPE V1  
MEMORANDUM**

**MARKS/PUNT: 150**

---

This memorandum consists of 13 pages./  
*Hierdie memorandum bestaan uit 13 bladsye.*

---

**GENERAL GUIDELINES/ALGEMENE RIGLYNE****1. CALCULATIONS/BEREKENINGE**

- 1.1 **Marks will be awarded for:** correct formula, correct substitution, correct answer with unit.  
*Punte sal toegeken word vir: korrekte formule, korrekte substitusie, korrekte antwoord met eenheid.*
- 1.2 **No marks** will be awarded if an **incorrect or inappropriate formula is used**, even though there are many relevant symbols and applicable substitutions.  
*Geen punte sal toegeken word waar 'n verkeerde of ontoepaslike formule gebruik word nie, selfs al is daar relevante simbole en relevante substitusies.*
- 1.3 When an error is made during **substitution into a correct formula**, a mark will be awarded for the correct formula and for the correct substitutions, but **no further marks** will be given.  
*Wanneer 'n fout gedurende substitusie in 'n korrekte formule began word, sal 'n punt vir die korrekte formule en vir korrekte substitusies toegeken word, maar geen verdere punte sal toegeken word nie.*
- 1.4 If **no formula** is given, but **all substitutions are correct**, a candidate will **forfeit one mark**.  
*Indien geen formule gegee is nie, maar al die substitusies is korrek, verloor die kandidaat een punt.*
- 1.5 **No penalisation** if **zero substitutions are omitted** in calculations where **correct formula/principle** is correctly given.  
*Geen penalisering indien nulwaardes nie getoon word nie in berekeninge waar die formule/beginsel korrek gegee is nie.*
- 1.6 Mathematical manipulations and change of subject of appropriate formulae carry no marks, but if a candidate starts off with the correct formula and then changes the subject of the formula incorrectly, marks will be awarded for the formula and correct substitutions. The mark for the incorrect numerical answer is forfeited.  
*Wiskundige manipulasies en verandering van die onderwerp van toepaslike formules tel geen punte nie, maar indien 'n kandidaat met die korrekte formule begin en dan die onderwerp van die formule verkeerde verander, sal die punte vir die formule en korrekte substitusies toegeken word. Die punt vir die verkeerde numeriese antwoord word verbeur.*
- 1.7 Marks are only awarded for a formula if a **calculation has been attempted**, i.e. substitutions have been made or a numerical answer given.  
*Punte word slegs vir 'n formule toegeken indien 'n poging tot 'n berekening aangewend is, d.w.s. substitusies is gedoen of 'n numeriese antwoord is gegee.*
- 1.8 Marks can only be allocated for substitutions when values are substituted into formulae and not when listed before a calculation starts.  
*Punte kan slegs toegeken word vir substitusies wanneer waardes in formules ingestel word en nie vir waardes wat voor 'n berekening gelys is nie.*

- 1.9 All calculations, when not specified in the question, must be done to a minimum of two decimal places.  
*Alle berekenings, wanneer nie in die vraag gespesifiseer word nie, moet tot 'n minimum van twee desimale plekke gedoen word.*
- 1.10 If a final answer to a calculation is correct, full marks will not automatically be awarded. Markers will always ensure that the correct/appropriate formula is used and that workings, including substitutions, are correct.  
*Indien 'n finale antwoord van 'n berekening korrek is, sal volpunte nie outomaties toegeken word nie. Nasieners sal altyd verseker dat die korrekte/toepaslike formule gebruik word en dat bewerkings, insluitende substitusies korrek is.*
- 1.11 Questions where a series of calculations have to be made (e.g. a circuit diagram question) do not necessarily always have to follow the same order. FULL MARKS will be awarded provided it is a valid solution to the problem. However, any calculation that will not bring the candidate closer to the answer than the original data, will no count any marks.  
*Vrae waar 'n reeks berekeninge gedoen moet word (bv. 'n stroombaan-diagramvraag) hoef nie noodwendig dieselfde volgorde te hê nie. VOLPUNTE sal toegeken word op voorwaarde dat dit 'n geldige oplossing vir die probleem is. Enige berekening wat egter nie die kandidaat nader aan die antwoord as die oorspronklike data bring nie, sal geen punte tel nie.*

## 2. UNITS/EENHEDE

- 2.1 Candidates will only be penalised once for the repeated use of an incorrect unit **within a question**.  
*Kandidate sal slegs een keer gepenaliseer word vir die herhaaldelike gebruik van 'n verkeerde eenheid **in 'n vraag**.*
- 2.2 Units are only required in the final answer to a calculation.  
*Eenhede word slegs in die finale antwoord op 'n vraag verlang.*
- 2.3 Marks are only awarded for an answer, and not for a unit *per se*. Candidates will therefore forfeit the mark allocated for the answer in each of the following situations:
- Correct answer + wrong unit
  - Wrong answer + correct unit
  - Correct answer + no unit
- Punte sal slegs vir 'n antwoord en nie vir 'n eenheid per se toegeken word nie. Kandidate sal die punt vir die antwoord in die volgende gevalle verbeur:*
- *Korrekte antwoord + verkeerde eenheid*
  - *Verkeerde antwoord + korrekte eenheid*
  - *Korrekte antwoord + geen eenheid*
- 2.4 SI units must be used except in certain cases, e.g.  $V \cdot m^{-1}$  instead of  $N \cdot C^{-1}$ , and  $cm \cdot s^{-1}$  or  $km \cdot h^{-1}$  instead of  $m \cdot s^{-1}$  where the question warrants this.  
*SI eenhede moet gebruik word, behalwe in sekere gevalle, bv.  $V \cdot m^{-1}$  in plaas van  $N \cdot C^{-1}$ , en  $cm \cdot s^{-1}$  of  $km \cdot h^{-1}$  in plaas van  $m \cdot s^{-1}$  waar die vraag dit regverdig.*

### 3. GENERAL/ALGEMEEN

- 3.1 If one answer or calculation is required, but two are given by the candidate, only the first one will be marked, irrespective of which one is correct. If two answers are required, only the first two will be marked, etc.

*Indien een antwoord of berekening verlang word, maar twee word deur die kandidaat gegee, sal slegs die eerste een nagesien word, ongeag watter een korrek is. Indien twee antwoorde verlang word, sal slegs die eerste twee nagesien word, ens.*

- 3.2 For marking purposes, alternative symbols (s, u, t etc) will also be accepted.  
*Vir nasiendoeleindes sal alternatiewe simbole (s, u, t ens) ook aanvaar word.*

- 3.3 Separate compound units with a multiplication dot, no a full stop, for example,  $m \cdot s^{-1}$ . For marking purposes,  $m \cdot s^{-1}$  and  $m/s$  will also be accepted.  
*Skei saamgestelde eenhede met 'n vermenigvuldigingspunt en nie met 'n punt nie, byvoorbeeld  $m \cdot s^{-1}$ . Vir nasiendoeleindes sal  $m \cdot s^{-1}$  en  $m/s$  ook aanvaar word.*

### 4. POSITIVE MARKING/POSITIEWE NASIEN

Positive marking regarding calculations will be followed in the following cases:  
*Positiewe nasien met betrekking tot berekeninge sal in die volgende gevalle geld:*

- 4.1 **Subquestion to subquestion:** When a certain variable is calculated in one subquestion (e.g. 3.1) and needs to be substituted in another (3.2 or 3.3), e.g. if the answer for 3.1 is incorrect and is substituted correctly in 3.2 or 3.3, **full marks** are to be awarded for the subsequent subquestions.

**Subvraag na subvraag:** *Wanneer 'n sekere veranderlike in een subvraag (bv. 3.1) bereken word en dan in 'n ander vervang moet word (3.2 of 3.3), bv. indien die antwoord vir 3.1 verkeerd is en word korrek in 3.2 of 3.3 vervang, word **volpunte** vir die daaropvolgende subvraag toegeken.*

- 4.2 **A multistep question in a subquestion:** If the candidate has to calculate, for example, current in the first step and gets it wrong due to a substitution error, the mark for the substitution and the final answer will be forfeited.

**'n Vraag met veelvuldige stappe in 'n subvraag:** *Indien 'n kandidaat bv. die stroom verkeerd bereken in 'n eerste stap as gevolg van 'n substitusiefout, verloor die kandidaat die punt vir die substitusie sowel as die finale antwoord.*

### 5. NEGATIVE MARKING/NEGATIEWE NASIEN

Normally an incorrect answer cannot be correctly motivated if based on a conceptual mistake. If the candidate is therefore required to motivate in QUESTION 3.2 the answer given in QUESTION 3.1, and 3.1 is incorrect, no marks can be awarded for QUESTION 3.2. However, if the answer for e.g. 3.1 is based on a calculation, the motivation for the incorrect answer could be considered.

*'n Verkeerde antwoord, indien dit op 'n konsepsuele fout gebaseer is, kan normaalweg nie korrek gemotiveer word nie. Indien 'n kandidaat gevra word om in VRAAG 3.2 die antwoord op VRAAG 3.1 te motiveer en 3.1 is verkeerd, kan geen punte vir VRAAG 3.2 toegeken word nie. Indien die antwoord op bv. 3.1 egter op 'n berekening gebaseer is, kan die motivering vir die verkeerde antwoord in 3.2 oorweeg word.*

**QUESTION/VRAAG 1**

- 1.1 A ✓✓ (2)
- 1.2 C ✓✓ (2)
- 1.3 C ✓✓ (2)
- 1.4 C ✓✓ (2)
- 1.5 B ✓✓ (2)
- 1.6 C ✓✓ (2)
- 1.7 A ✓✓ (2)
- 1.8 D ✓✓ (2)
- 1.9 A ✓✓ (2)
- 1.10 B ✓✓ (2)
- [20]**

## QUESTION/VRAAG 2

2.1  $W = mg \checkmark = 122,5 \times 9,8 \checkmark = 1\,200,50 \text{ N} \checkmark$  (3)

2.2.1

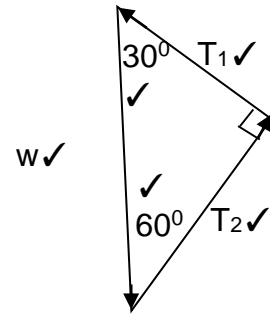
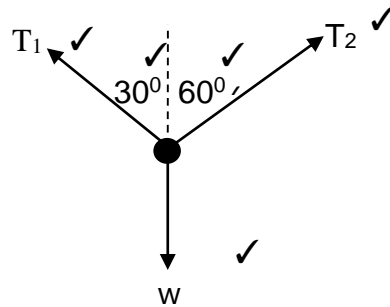

(5)

2.2.2 **Option/Opsie 1:**

$$\cos 30^\circ = \frac{T_{1y}}{T_1} \checkmark$$

(resolve vectors/los vektore op)

$$T_{1y} = T_1 \cdot \cos 30^\circ$$

$$\cos 60^\circ = \frac{T_{2y}}{T_2}$$

$$T_{2y} = T_2 \cdot \cos 60^\circ$$

$$T_{1y} + T_{2y} = w \checkmark$$

$$T_1 \cos 30^\circ + T_2 \cos 60^\circ = 1200,50 \checkmark \quad .(1)$$

$$T_1 \sin 30^\circ = T_2 \sin 60^\circ \checkmark \quad .(2)$$

$$\text{From (2):} \quad T_2 = \frac{T_1 \sin 30^\circ}{\sin 60^\circ}$$

$$T_1 \cos 30^\circ + \frac{T_1 \sin 30^\circ}{\sin 60^\circ} \cdot \cos 60^\circ \checkmark = 1200,50$$

$$T_1 = 1\,039,66 \text{ N} \checkmark$$

$$T_2 = \frac{1039,66 \sin 30^\circ}{\sin 60^\circ}$$

$$T_2 = 600,25 \text{ N} \checkmark$$

**Option/Opsie 2**

$$\frac{T_1}{\sin 60^\circ} = \frac{w}{\sin 90^\circ} \checkmark$$

(sine rule/sin reël)

$$\frac{T_1}{\sin 60^\circ} = \frac{1200,50}{\sin 90^\circ} \checkmark$$

$$T_1 = \frac{1200,50 \sin 60^\circ}{\sin 90^\circ} \checkmark$$

$$T_1 = 1039,66 \text{ N} \checkmark$$

$$\frac{T_2}{\sin 30^\circ} \checkmark = \frac{1200,50}{\sin 90^\circ}$$

$$T_2 = \frac{1200,50 \sin 30^\circ}{\sin 90^\circ} \checkmark$$

$$T_2 = 600,25 \text{ N} \checkmark$$

(7)

2.3.1  $F_{\text{net}} = 0$ /Balanced/at equilibrium/opposite forces are equal.  $\checkmark \checkmark$

$F_{\text{net}} = 0$ /Balanseer/by ewewig/teenoorgestelde kragte is gelyk. (2)

2.3.2 Newton's first law of motion/Newton se eerste bewegingswet  $\checkmark \checkmark$  (2)

[19]

## QUESTION/VRAAG 3

3.1

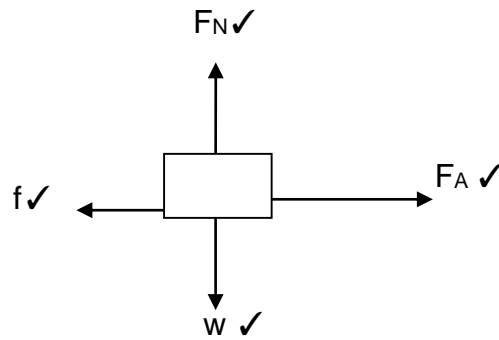

(4)

- 3.2 When a resultant/net force acts on an object, the object will accelerate in the direction of the force at an acceleration that is directly proportional to the force ✓ and inversely proportional to the mass of the object. ✓  
*Wanneer 'n resulterende/netto krag op 'n voorwerp inwerk, versnel die voorwerp in die rigting van die krag teen 'n versnelling direk eweredig aan die krag en omgekeerde eweredig aan die massa van die voorwerp.*

**OF/OR**

The resultant/net force on an object is equal to the rate of change in momentum. ✓ ✓

*Die resulterende/netto krag wat op 'n voorwerp inwerk is gelyk aan die tempo van die verandering van momentum.*

(2)

3.3.1 **UPWARDS AS POSITIVE/OPWAARTS AS POSITIEF**

$$F_{\text{net}} = 0 \quad \checkmark$$

$$F_N + (-W) = 0 \quad \checkmark$$

$$F_N + (-mg) = 0$$

$$F_N + (5)(-9,8) \quad \checkmark = 0$$

$$F_N = 49 \text{ N} \quad \checkmark \text{ upwards/opwaarts}$$

(4)

3.3.2  $f_k = \mu_k \cdot F_N \quad \checkmark$ 

$$= (0,4)(49) \quad \checkmark$$

$$= 19,6 \text{ N} \quad \checkmark$$

(3)

3.4  $F_{\text{net}} = F_A + f_k \quad \checkmark$ 

$$= 25 + (-19,6) \quad \checkmark$$

$$= 5,40 \text{ N}$$

$$a = \frac{F_{\text{net}}}{m} = \frac{5,40}{5} \quad \checkmark$$

$$= 1,08 \text{ m}\cdot\text{s}^{-2} \quad \checkmark$$

(4)

**[17]**

## QUESTION/VRAAG 4

4.1.1

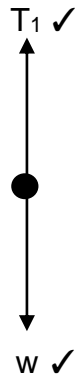

(2)

4.1.2 UPWARDS AS POSITIVE/OPWAARTS AS POSITIEF

$$F_{\text{net}} = 0 \checkmark$$

$$T_1 + (-w) \checkmark = 0$$

$$T_1 + (-mg) = 0$$

$$T_1 + (3)(-9,8) \checkmark = 0$$

$$T_1 = 29,40 \text{ N}$$

$$T_1 = 29,40 \text{ N} \checkmark \text{ upwards/opwaarts}$$

(4)

4.2

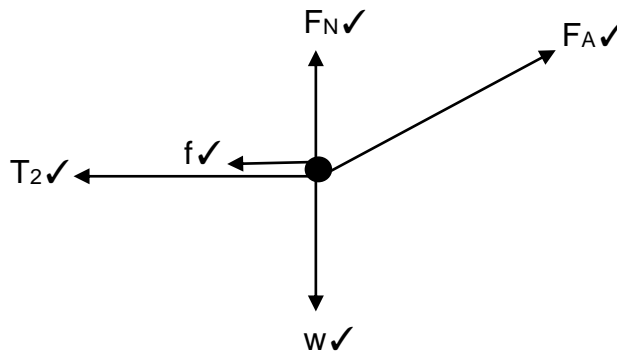

(5)

4.3  $T_2 = 29,40 \text{ N} \checkmark$

(1)

4.4 Right is positive/Regs as positief

$$F_{\text{net}} = 0 \checkmark$$

$$f + (-T_2) + (F_A \cos 30^\circ) \checkmark = 0$$

$$f - 29,40 \checkmark + 36 \cos 30^\circ = 0 \checkmark$$

$$f = -1,78 \text{ N}$$

$$= 1,78 \text{ N left/links} \checkmark$$

(5)

[17]

## QUESTION/VRAAG 5

- 5.1 Every body in the universe attracts every other body with a force that is directly proportional to the product of their masses ✓ and inversely proportional to the square of the distance between their centres. ✓  
*Elke liggaam in die heelal trek elke ander liggaam aan met 'n krag wat direk eweredig aan die produk van hul massas en omgekeerde eweredig is aan die kwadraat van die afstand tussen hul middelpunte.* (2)

- 5.2 Equal to/Gelyk aan ✓ (1)

- 5.3 When body A exerts a force on a body B, body B exerts a force of equal magnitude ✓ in the opposite direction ✓ on body A.  
*Wanneer liggaam A 'n krag uitoefen op liggaam B, oefen liggaam B 'n krag van gelyke grootte in die teenoorgestelde rigting op liggaam A uit.*

## OR/OF

If body A exerts a force on object B, then body B exerts an equal ✓ and opposite force ✓ on body A.  
*Indien liggaam A 'n krag uitoefen op liggaam B, dan sal liggaam B 'n gelyke maar teenoorgestelde krag op liggaam A uitoefen.*

**Accept/Aanvaar:**

For every action, there is an equal ✓ and opposite reaction. ✓  
*Vir elke aksie is daar 'n gelyke en teenoorgestelde reaksie.*

**OR/OF**

Action and reaction are equal ✓ and opposite. ✓  
*Aksie en reaksie is gelyk maar teenoorgesteld.* (2)

- 5.4 Increase. ✓  $F_{net}$  is inversely proportional to the square of the distance between their centres. ✓ Acceleration is directly proportional to  $F_{net}$ . ✓  
*Toeneem.  $F_{net}$  is omgekeerd eweredig aan die kwadraat van die afstand tussen hul middelpunte. Versnelling is direk eweredig aan  $F_{net}$ .* (3)

- 5.5 
$$F = \frac{GM_E M_C}{r^2} \checkmark$$

$$F = \frac{(6,67 \times 10^{-11})(6 \times 10^{24}) \checkmark (1 \times 10^{15}) \checkmark}{(1,3 \times 10^{11})^2 \checkmark}$$

$$= 2,37 \times 10^7 \text{ N } \checkmark \text{ attraction/aantrekkend} \quad (5)$$
**[13]**

**QUESTION/VRAAG 6**

6.1 To identify the unknown material. ✓ ✓ / Om die onbekende stof te identifiseer. (2)

6.2.1 Angle of incidence ✓ / Invalshoek (1)

6.2.2 Angle of refraction ✓ / Brekingshoek (1)

$$6.3.1 \quad n_1 \sin \theta_1 = n_2 \sin \theta_2 \quad \checkmark$$

$$n_2 = \frac{1 \sin 5^\circ \checkmark}{\sin 3,76^\circ \checkmark}$$

$$= 1,33 \quad \checkmark$$

**Note/Aantekeninge:**

- Any set in TABLE 6.1 can be used./ Enige stel kan in TABEL 6.1 gebruik word.
- Answer range/Antwoord reikwydte (0,97-1,37)

(4)

6.3.2 Water: liquid ✓ / Water: vloeistof

**Note/Aantekeninge:**

- Take answer of QUESTION 6.3.1 and compare it to the closest values in TABLE 6.2. in order to identify the unknown material.  
Neem die antwoord van VRAAG 6.3.1 en vergelyk dit met die naaste waardes in TABEL 6.2 om die onbekende stof te identifiseer.

(1)

$$6.4 \quad n_1 \sin \theta_c = n_2 \sin 90^\circ \quad \checkmark$$

$$\sin \theta_c = \frac{1 \sin 90^\circ \quad \checkmark}{1,54 \quad \checkmark}$$

$$\theta_c = \sin^{-1} \left( \frac{1 \sin 90^\circ}{1,54} \right) \quad \checkmark$$

$$= 40.49^\circ \quad \checkmark$$

(5)

**[14]**

**QUESTION/VRAAG 7**

- 7.1 The ability of a wave to spread out ✓ in wave fronts as they pass through a small aperture/barrier/opening/slit or around a sharp edge. ✓  
*Die vermoë van 'n golf om in golf fronte uit te sprei soos hulle deur 'n klein versperring/opening/spleet of om 'n skerp kant beweeg.* (2)
- 7.2 Every point on a wave front acts as a source of secondary/new wavelets which spread out as in all directions with the same speed as the wave itself. ✓ ✓  
*Elke punt op 'n golf front reageer soos 'n bron van sekondêre/nuwe golfies wat in alle rigtings met dieselfde spoed as die golf uitsprei.* (2)
- 7.3.1 Bright bands-Constructive ✓ and Dark bands-destructive interference. ✓  
*Helder bande-Konstruktiewe en Donker bande-destruktiewe interferensie.* (2)
- 7.3.2 BROADER ✓ ✓ /BRËER (2)
- 7.4.1 DECREASES ✓ /NEEM TOE (1)
- 7.4.2 DECREASES ✓ /NEEM TOE (1)
- [10]**

## QUESTION/VRAAG 8

- 8.1 The magnitude of the electrostatic force exerted by one point charge ( $Q_1$ ) on another point charge ( $Q_2$ ) is directly proportional to the product of the (magnitude of the) charges ✓ and inversely proportional to the square of the distance between them. ✓

*Die grootte van die elektrostatiese krag wat deur een puntlading ( $Q_1$ ) op 'n ander puntlading ( $Q_2$ ) uitoefen word, is direk eweredig aan die produk van die (grootte van die) ladings en omgekeerd eweredig aan die kwadraat van die afstand tussen hulle.*

(2)

8.2

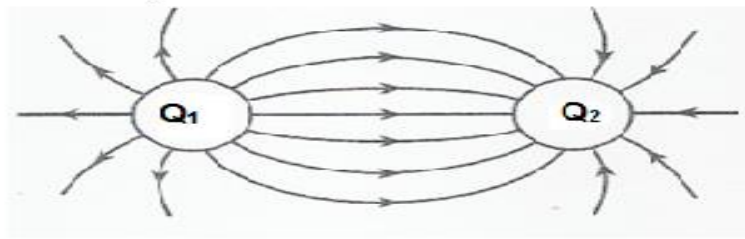

Criteria for sketch/Kriteria vir skets.	Marks/Punte
Correct shape Korrekte vorm.	✓
Direction from positive to negative. Rigting van positief na negatief.	✓
Field lines start on spheres and do not cross. Veldlyne begin op sferes en kruis nie.	✓

(3)

8.3.1

$$F = \frac{kQ_1 Q_2}{r^2} \checkmark$$

$$F = \frac{(9,0 \times 10^9)(6 \times 10^{-6}) \checkmark (4 \times 10^{-6}) \checkmark}{(3)^2 \checkmark}$$

$$F = 2,4 \times 10^{-2} \text{ N right/regs } \checkmark$$

(no direction/geen rigting- 4/5)

(5)

8.3.2

$$E_1 = \frac{kQ_1}{r^2} \checkmark = \frac{(9,0 \times 10^9)(6 \times 10^{-6}) \checkmark}{(4,2)^2 \checkmark} = 3\,061,22 \text{ N.C}^{-1}$$

$$E_2 = \frac{kQ_2}{r^2} = \frac{(9,0 \times 10^9)(4 \times 10^{-6}) \checkmark}{(1,2)^2} = 25\,000 \text{ N.C}^{-1}$$

$$\begin{aligned} E_{\text{net}} &= E_1 + (-E_2) \checkmark \\ &= 3\,061,22 + (-25\,000) \checkmark \\ &= -2,19 \times 10^4 \\ &= 2,19 \times 10^4 \text{ N.C}^{-1} \text{ left/links } \checkmark \end{aligned}$$

(7)

$$8.3.3 \quad n_{e^-} = \frac{Q_2}{Q_e} = \frac{(4 \times 10^{-6})}{(1,6 \times 10^{-19})} \checkmark = 2,5 \times 10^{13} \text{ electrons } \checkmark / \text{elektrone}$$

(2)  
[19]**QUESTION/VRAAG 9**

9.1 The potential difference (voltage) across a conductor is directly proportional to the current  $\checkmark$  in the conductor at constant temperature.  $\checkmark$

*Die potensiaalverskil oor 'n geleier is direk eweredig aan die stroom in die geleier by konstante temperatuur.*

**OF/OR**

Ratio of potential difference to current is constant  $\checkmark$  **at constant temperature.**  $\checkmark$

*Die verhouding van die potensiaalverskil tot stroom is konstant by konstante temperatuur.*

(2)

9.2 **Option/Opsie 1**

$$R_p = \frac{(R_A \times R_B)}{(R_A + R_B)} \checkmark$$

$$2 \checkmark = \frac{(6 R_B) \checkmark}{(6 + R_B) \checkmark}$$

$$2(6 + R_B) = 6R_B$$

$$12 + 2R_B = 6R_B$$

$$R_B = 3 \Omega \checkmark$$

**Option/Opsie 2**

$$\frac{1}{R_p} = \frac{1}{R_A} + \frac{1}{R_B} \checkmark$$

$$\frac{1}{2} \checkmark = \frac{1}{6} \checkmark + \frac{1}{R_B} \checkmark$$

$$\frac{1}{R_B} = \frac{1}{2} - \frac{1}{6}$$

$$\frac{1}{R_B} = \frac{2}{6}$$

$$R_B = 3 \Omega \checkmark$$

(5)

9.3  $R_T = R_P + R_S \checkmark$

$$= 2 \checkmark + 6 \checkmark$$

$$= 8 \Omega \checkmark$$

$$I = \frac{V}{R} \checkmark = \frac{24}{8} \checkmark = 3A \checkmark$$

(7)

9.4 **Option/Opsie 1**

$$V_P = IR_p \checkmark$$

$$= 3 \checkmark \times 2 \checkmark$$

$$= 6 V \checkmark$$

$$V_p = V_A \checkmark = V_B$$

$$V_A = 6 V \checkmark \checkmark \text{ (2 or 0 marks/punte)}$$

**Option/Opsie 2**

$$V_C = IR_6 \checkmark$$

$$= 3 \checkmark \times 6 \checkmark$$

$$= 18 V \checkmark$$

$$V_T = V_p + V_C \checkmark$$

$$24 = V_p + 18$$

$$V_p = 6 V \checkmark \checkmark \text{ (2 or 0 marks/punte)}$$

(7)

[21]

**TOTAL/TOTAAL: 150**