



Basic Education

KwaZulu-Natal Department of Basic Education
REPUBLIC OF SOUTH AFRICA

MATHEMATICS P2

COMMON TEST

JUNE 2016

**NATIONAL
SENIOR CERTIFICATE**

GRADE 11

MARKS: 100

TIME: 2 hours

This question paper consists of 8 pages and 3 diagram sheets.

INSTRUCTIONS AND INFORMATION

Read the following instruction carefully before answering the questions.

1. The question paper consists of 6 questions.
2. Answer **ALL** the questions.
3. Clearly show all calculations and diagrams that you have used in determining your answers.
4. You may use an approved scientific calculator (non-programmable and non-graphical).
5. If necessary round off answers to **TWO** decimal places, unless otherwise stated.
6. Answers only will not be awarded full marks.
7. Diagrams not necessarily drawn to scale.
8. Number the answers correctly according to the numbering system used in this question paper.
9. Write neatly and legibly.

QUESTION 1

1.1 In the diagram below PQRS is a square with sides of 5 units. The coordinates of R is $(1; -2)$. PQ is parallel to the x -axis.

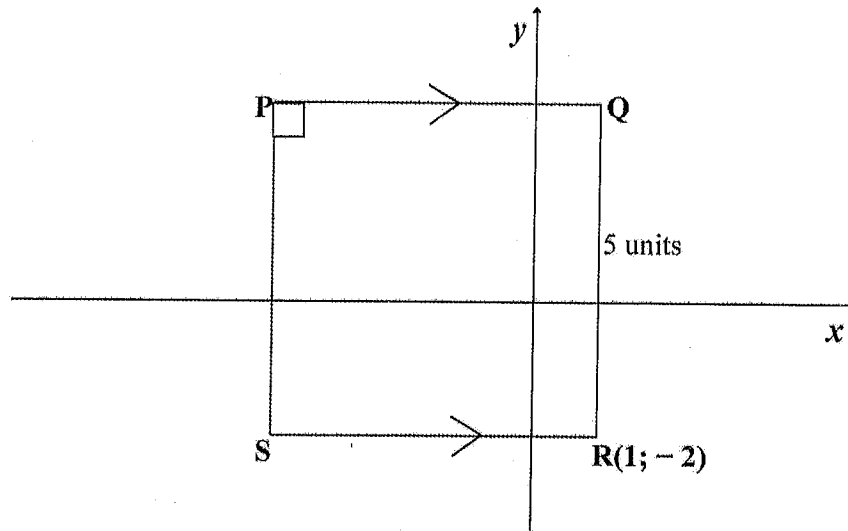

- 1.1.1 Write down the coordinates of Q. (1)
- 1.1.2 Write down the coordinates of S. (1)
- 1.1.3 Write down the equation of PQ. (1)
- 1.1.4 Write down the equation of QR. (1)

1.2 In the sketch below $A(0; 4)$, $B(-4; -3)$ and $C(4; -2)$ are the vertices of $\triangle ABC$. K is the midpoint of AC. AT is drawn with T a point on the x -axis, such that the acute angle between AT and the x -axis is equal to $26,6^\circ$. $S(p; 1)$ is a point on AT.

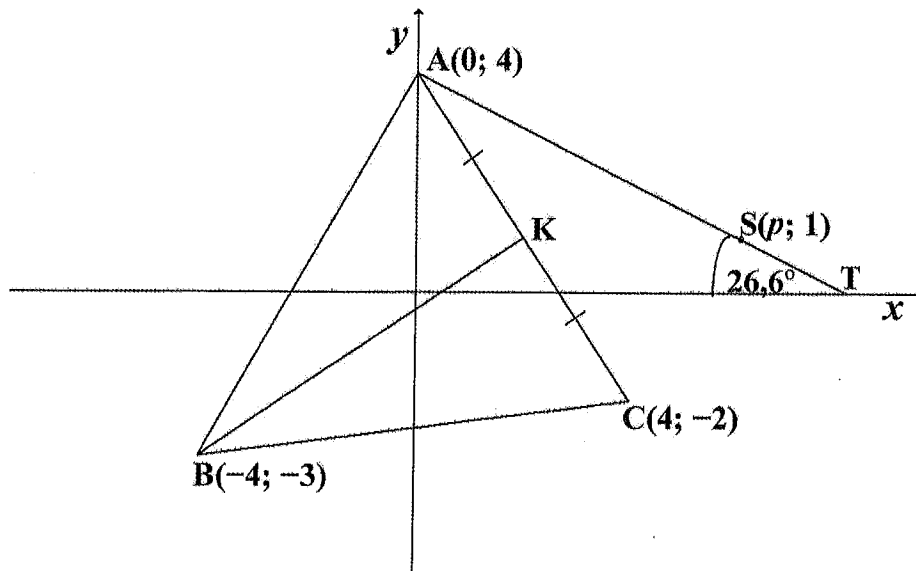

- 1.2.1 Determine the coordinates of point K. (2)
- 1.2.2 Calculate the length of AC, correct to 2 decimal places. (2)
- 1.2.3 Calculate the gradients of BK and AC and then show that $\hat{BKC} = 90^\circ$. (5)
- 1.2.4 Determine the equation of line BK. (3)
- 1.2.5 Calculate the area of $\triangle ABC$, correct to 2 decimal places. (5)
- 1.2.6 Calculate the value of p . (5)

[26]

QUESTION 2

- 2.1 PQRS is a parallelogram. The equation of PQ is $y = \frac{1}{4}x$.
The gradient of SP is equal to -1 . R is the point $(3; 2)$.

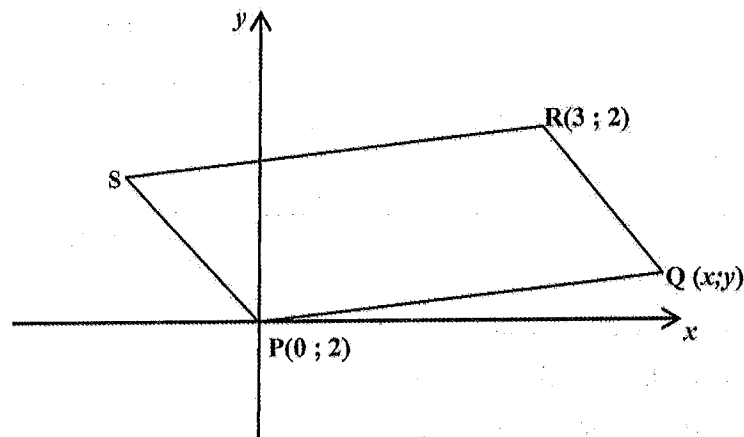

- 2.1.1 Write down the gradient of RQ. (1)
- 2.1.2 Determine the equation of RQ. (2)
- 2.1.3 Calculate the coordinates of point Q. (4)
- 2.1.4 Calculate the size of \hat{SPQ} . (5)
- 2.2 Given A $(6; 7)$, B $(0; -1)$ and C $(4; p)$.
Calculate
- 2.2.1 The length of AB. (2)
- 2.2.2 The value of p if $\mathbf{AB} = 2 \mathbf{BC}$, $p < 0$ (5)

[19]

N.B: Give reasons for your statements and calculations in Questions 3 – 6.

QUESTION 3

3.1 COMPLETE: The line drawn from the centre of a circle to the midpoint of a chord

..... (1)

3.2

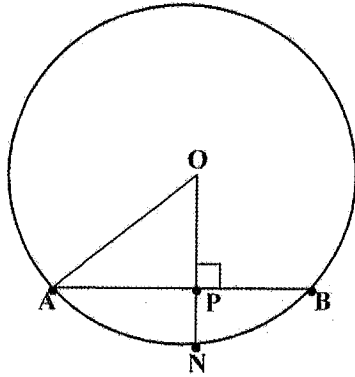

O is the centre of the circle. AB is a chord and $OP \perp AB$. OP is extended and intersects the circle at N. $AB = 16$ cm and $PN = 2$ cm. Let $OP = x$.

3.2.1 Calculate the length of AP. (2)

3.2.2 Calculate the length of the radius of the circle. (5)

[8]

QUESTION 4

- 4.1 In the figure below O is the centre of the circle and A, B and C are three points on the circumference of the circle. Use the figure and prove the theorem that states that $\hat{B}OC = 2\hat{A}$.

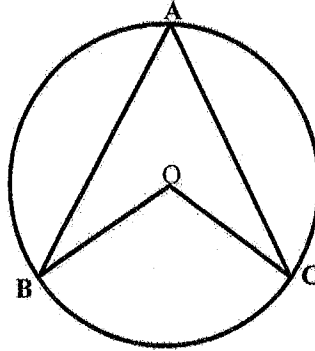

(6)

- 4.2 In the figure O is the centre of the circle and ABCD is a cyclic quadrilateral. DA is produced to F such that FA = AC and CB is produced to meet DF at F.

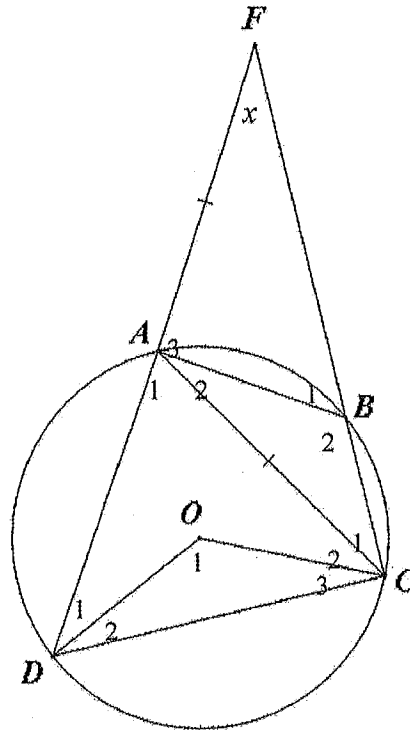

- 4.2.1 If $\hat{F} = x$, write down, with reasons, in terms of x ,

- (a) the size of \hat{A}_1 ; (4)
 (b) the size of \hat{O}_1 . (2)

- 4.2.2 If it is further given that FA = DA, find with reasons, the size of \hat{A}_3 . (6)

[18]

QUESTION 5

- 5.1 In the diagram below O is the centre of the circle. G, H, J and K are points on the circumference of the circle.
GOH is a diameter.
Chords GH, JH, KH, KJ and GK have also been drawn.
 $\hat{H}_1 = 26^\circ$.

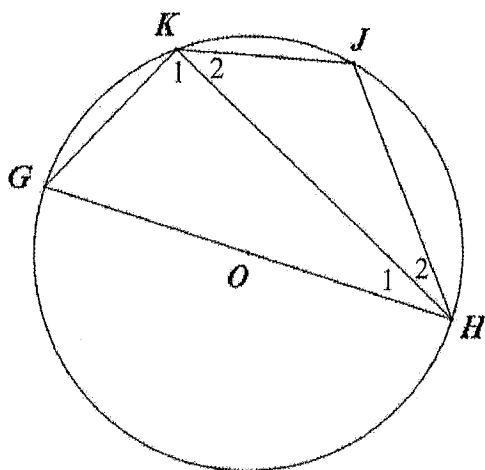

Calculate, with reasons, the size of

- 5.1.1 \hat{K}_1 . (1)
5.1.2 \hat{J} . (3)

- 5.2 GAFE and FCDE are two circles. Chords GA, AF, EF, CF, CD and DE are drawn. GFC is a straight line. DC produced meets GA produced at B.
 $\hat{E}_1 = 28^\circ$ and $\hat{E}_2 = 64^\circ$.

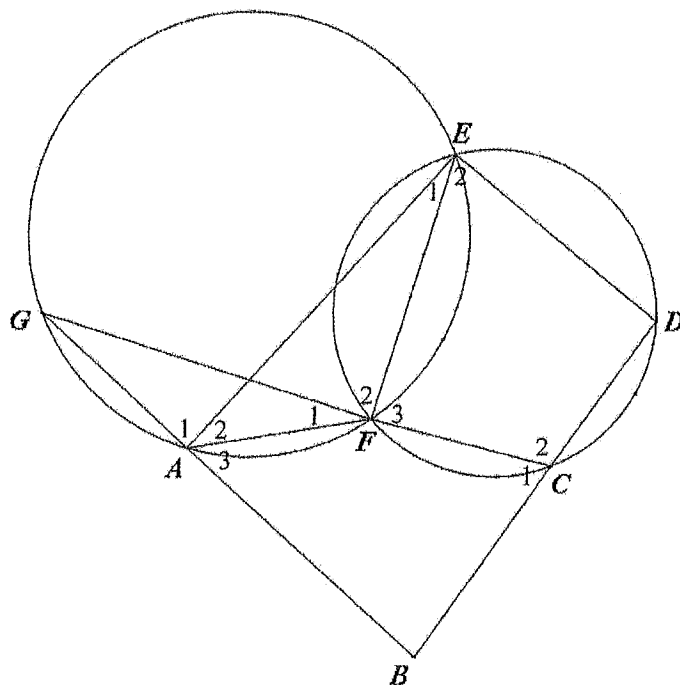

Calculate, with reasons, the size of

- 5.2.1 \hat{G} (2)
5.2.2 \hat{B} (4)

QUESTION 6

In the figure PR and PQ are two tangents drawn from point P to circle AQR. The straight line drawn through P parallel to AR meets QR produced at S, and QA produced at T. The tangent PR cuts QT at B.

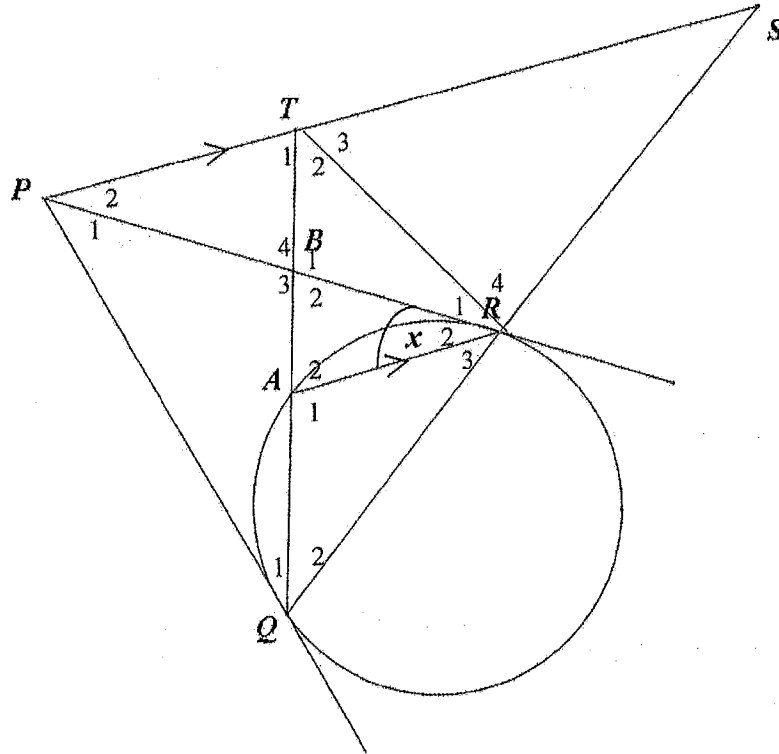

Let $\hat{R}_2 = x$

- 6.1 Prove that PTRQ is a cyclic quadrilateral. (5)
- 6.2 If it is further given that $QA = RA$, prove that:
 - 6.2.1 $\hat{S} = x$ (3)
 - 6.2.2 $PQ = RS$ (5)
 - 6.2.3 PTS is a tangent to circle TAR. (6)

[19]

TOTAL MARKS: [100]

DIAGRAM SHEETS: HAND IN WITH YOUR ANSWER BOOK

NAME: _____ GRADE: _____

QUESTION 1.2

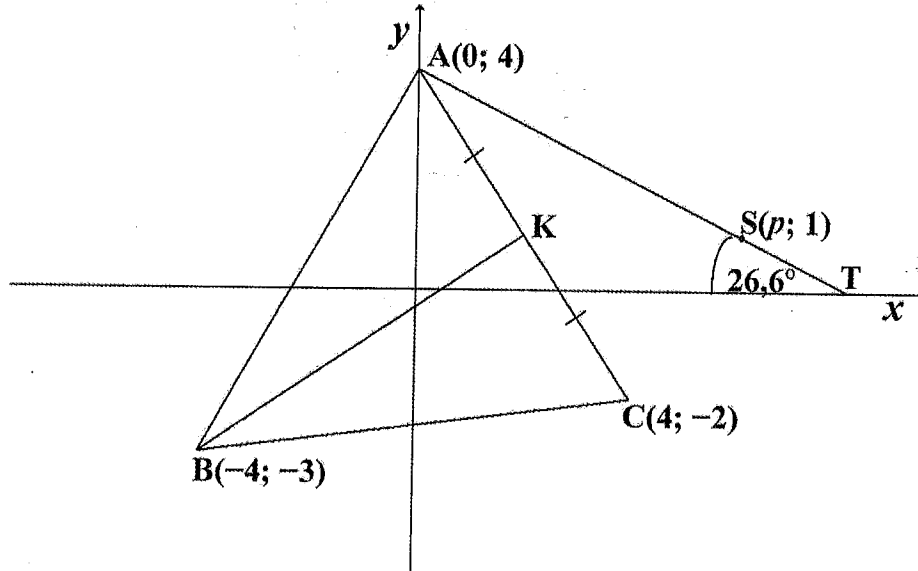

QUESTION 2.1

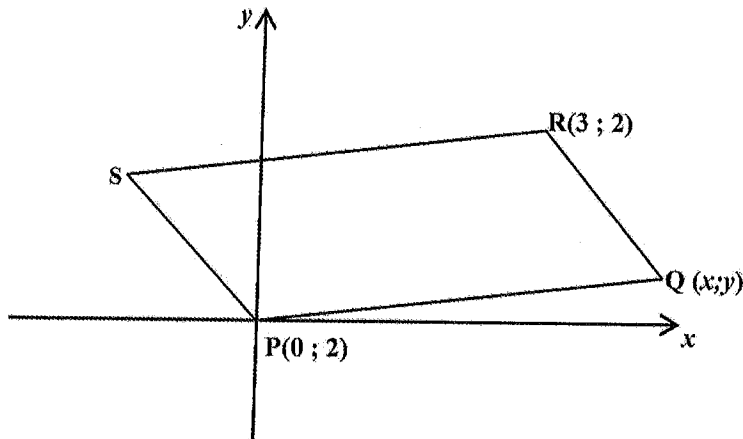

QUESTION 3.2

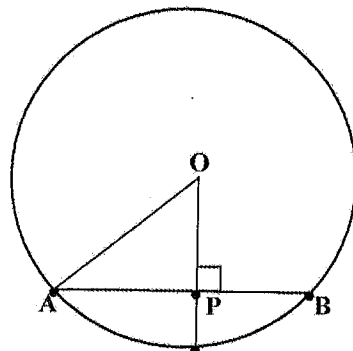

TEAR-OFF SHEET

QUESTION 4.1

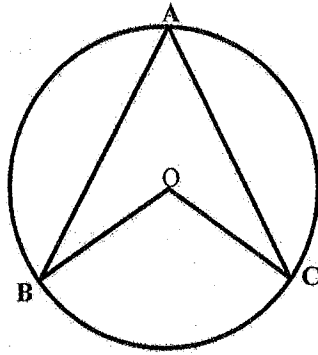

QUESTION 4.2

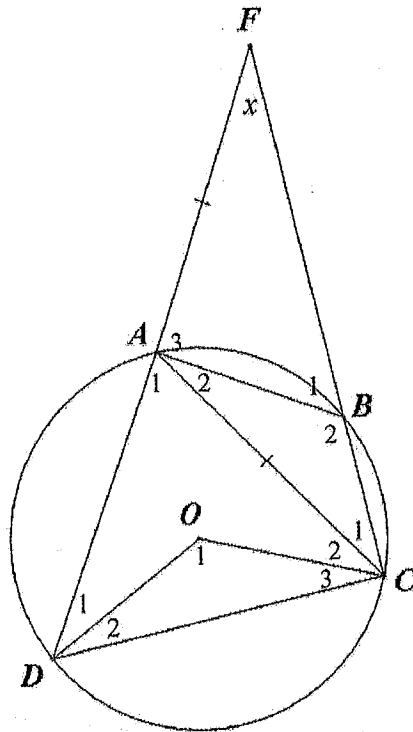

QUESTION 5.1

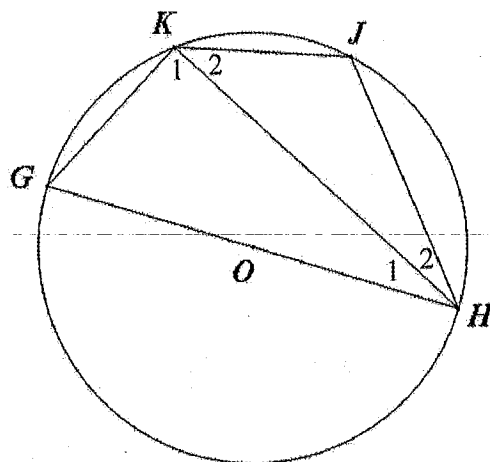

QUESTION 5.2

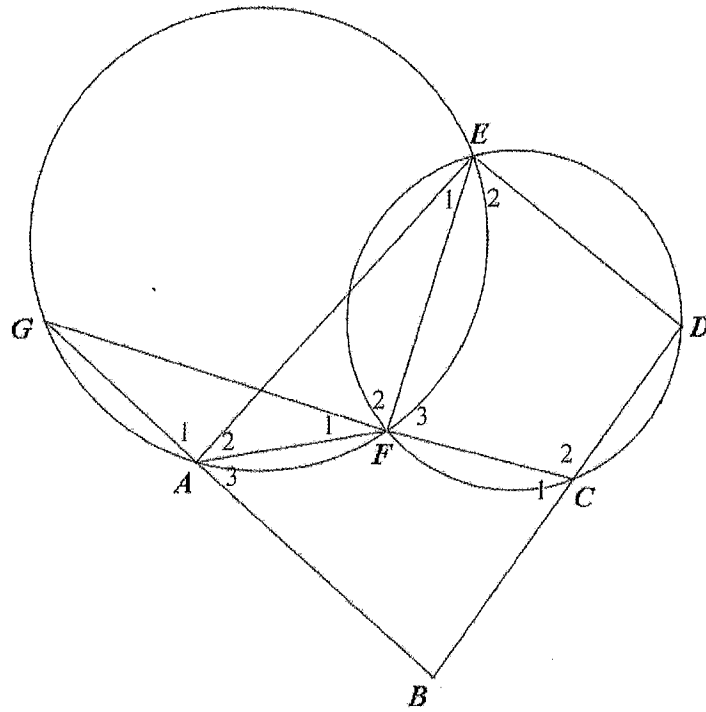

QUESTION 6

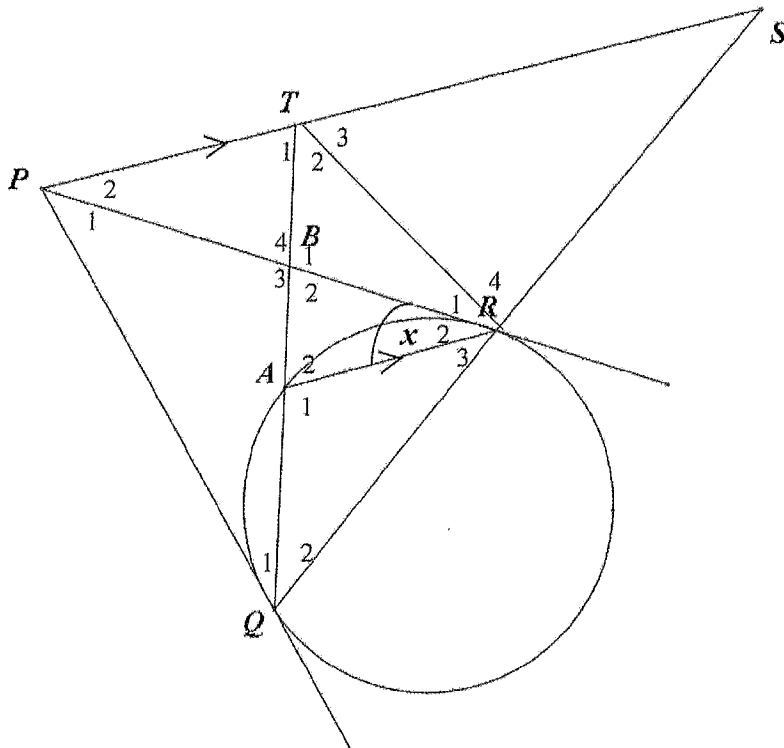

TEAR-OFF SHEET

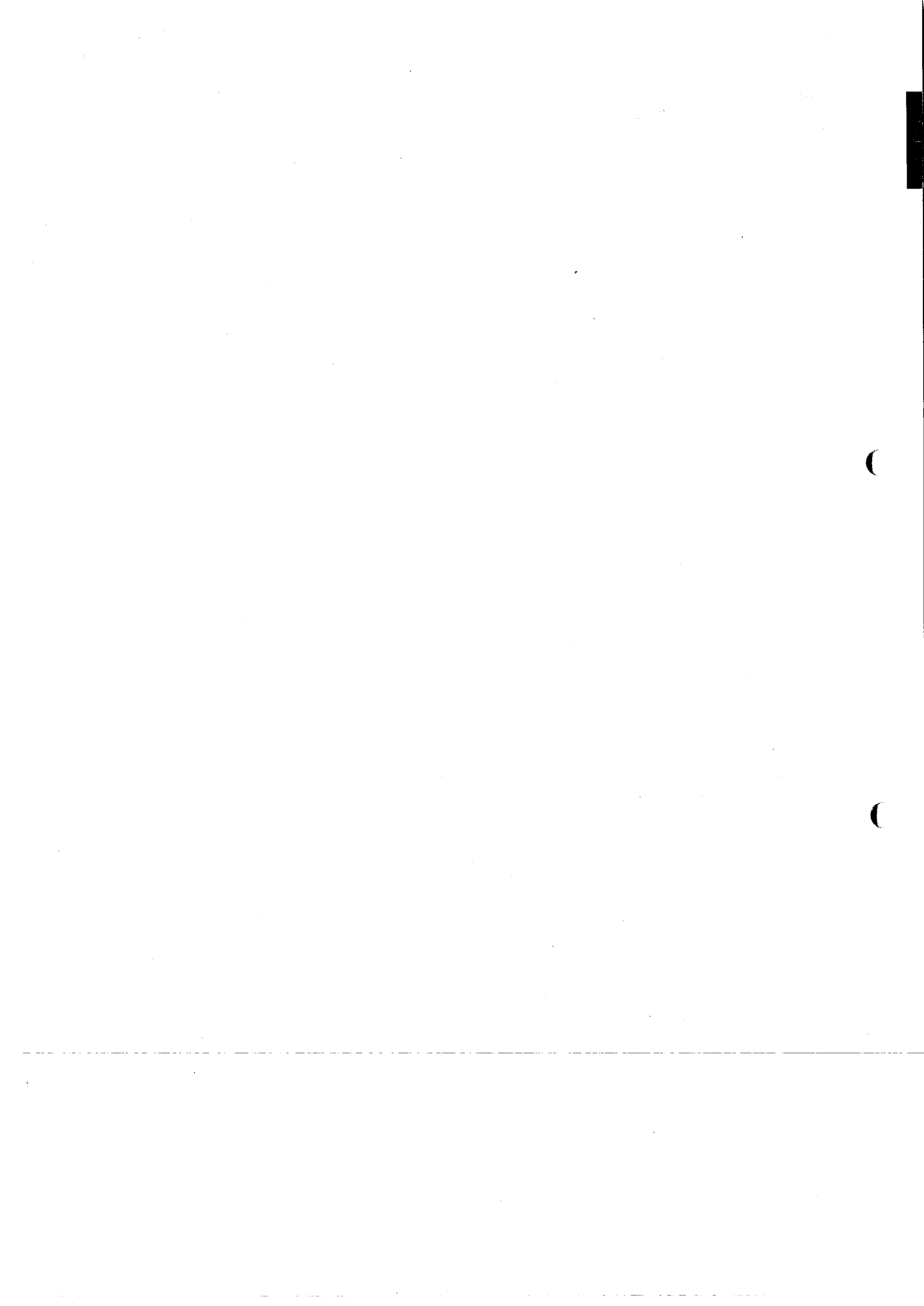



Basic Education

KwaZulu-Natal Department of Basic Education
REPUBLIC OF SOUTH AFRICA

MATHEMATICS P2

JUNE 2016

MARKING MEMORANDUM

**NATIONAL
SENIOR CERTIFICATE**

GRADE 11

MARKS : 100

This memorandum consists of 8 pages.

Symbol	Explanation
CA	Consistent accuracy
A	Accuracy
S	Statement
R	Reason
S/R	Statement with reason

QUESTIONS

1.1.1 Q(1;3)	IA for answer	(1)
1.1.2 S(-4; -2)	IA for answer	(1)
1.1.3 y = 3	IA for answer	(1)
1.1.4 x = 1	IA for answer	(1)
1.2.1 $\left(\frac{x_1 + x_2}{2}, \frac{y_1 + y_2}{2}\right)$ $= \left(\frac{0+4}{2}, \frac{4+(-2)}{2}\right)$ $= (2; 1) \checkmark$	IA for substitution ICA for answer	(2)
1.2.2 $AC = \sqrt{(x_2 - x_1)^2 + (y_2 - y_1)^2}$ $= \sqrt{(4 - 0)^2 + (-2 - 4)^2} \checkmark$ $= \sqrt{52}$ $= 7,21 \checkmark$	IA for substitution ICA for answer	(2)
1.2.3 $m_{BK} = \frac{y_2 - y_1}{x_2 - x_1}$ $= \frac{1 - (-3)}{2 - (-4)} \checkmark$ $= \frac{4}{6}$ $= \frac{2}{3} \checkmark$ $m_{AC} = \frac{-2 - 4}{4 - 0} \checkmark$ $= -\frac{6}{4}$ $= -\frac{3}{2} \checkmark$ $m_{BK} \times m_{AC} = \frac{2}{3} \times -\frac{3}{2} = -1 \checkmark$ $\therefore BK \perp AC \text{ or } \hat{BKC} = 90^\circ$	ICA for substitution ICA for value of m_{BK} ICA for substitution ICA for value of m_{AC} IA for showing that product of two gradients equals -1, and concluding	(5)

<p>1.2.4 $y = mx + c$ $= \frac{2}{3}x + c$ ✓ Substitute $(-4; -3)$: $-3 = \frac{2}{3}(-4) + c$ ✓ $c = -3 + \frac{8}{3} = -\frac{1}{3}$ $y = \frac{2}{3}x - \frac{1}{3}$ ✓ OR $y - y_1 = m(x - x_1)$ $= \frac{2}{3}(x - x_1)$ ✓ Substitute $(-4; -3)$: $y - (-3) = \frac{2}{3}[x - (-4)]$ ✓ $y + 3 = \frac{2}{3}x + \frac{8}{3}$ $y = \frac{2}{3}x - \frac{1}{3}$ ✓</p>	<p>1CA for substitution of gradient of BK 1CA for substitution of coordinates of B (or K) 1CA for answer (3) OR 1CA for substitution of gradient of BK 1CA for substitution of coordinates of B (or K) 1CA for answer (3)</p>
<p>1.2.5 Length of BK $= \sqrt{[2 - (-4)]^2 + [1 - (-3)]^2}$ ✓ $= \sqrt{6^2 + 4^2}$ $= \sqrt{52}$ $= 7,21$ ✓ Area of $\triangle ABC$ $= \frac{1}{2} \times \text{base} \times \text{height}$ ✓ $= \frac{1}{2} \times AC \times BK$ $= \frac{1}{2} \times 7,21 \times 7,21$ ✓ $= 25,99$ ✓</p>	<p>1CA for substitution 1CA for answer to length of BK 1A for formula 1CA for substitution 1CA for answer (also accept: 26) (5)</p>

<p>1.2.6 $m_{AT} = \tan 153,4^\circ$ $= -\tan 26,6^\circ$ $= -0,50$ ✓ Substitute $(0; 4)$ and find equation of AT: $y = mx + c$ $4 = -0,50(0) + c$ ✓ $c = 4$ $y = -0,50x + 4$ ✓ S lies on the line: $1 = -0,50(p) + 4$ ✓ $p = 6$ ✓</p>	<p>1A for gradient of AT 1CA for substitution of $(0; 4)$ and gradient 1CA for equation 1CA for substitution of $(p; 1)$ into equation 1CA for answer (5) [26]</p>
---	--

QUESTION 2

<p>2.1.1 $m_{PQ} = m_{PQ} = -1$ ✓</p>	<p>1A for equating gradients (1)</p>
<p>2.1.2 $y - y_1 = m(x - x_1)$ $y - 2 = -1(x - 3)$ ✓ $y = -x + 5$ ✓ OR $y = mx + c$ $2 = (-1)(3) + c$ ✓ $c = 5$ $y = -x + 5$ ✓</p>	<p>1A for substitution 1CA for equation OR 1CA for substitution 1CA for answer (2)</p>
<p>2.1.3 $-x + 5 = \frac{1}{4}x$ ✓ $4x + 20 = x$ ✓ $-5x = -20$ $x = 4$ ✓ $y = 1$ ✓ Q(4; 1)</p>	<p>1CA for equating the equations 1 CA for simplification 1CA for value of x 1CA for value of y (4)</p>

<p>2.1.4 $\tan XPQ = \frac{1}{4} \checkmark$ $XPQ = 14,04^\circ \checkmark$ $\tan XPS = -1$ $XPS = 135^\circ \checkmark$ $SPQ = 135^\circ - 14,04^\circ \checkmark$ $SPQ = 120, 96^\circ \checkmark$</p>	<p>1A for substitution in correct equation 1A for correct angle 1A for correct angle ICA for subtraction ICA for answer (5)</p>
<p>2.2.1 $AB = \sqrt{(6-0)^2 + (7+1)^2} \checkmark$ $= 10 \checkmark$</p>	<p>1A for substitution 1A for answer (2)</p>
<p>2.2.2 $AB = 2 BC$ $AB^2 = (2 BC)^2 \checkmark$ $100 = 4 [(0-4)^2 + (-1-p)^2] \checkmark$ $100 = 68 + 8p + 4p^2$ $4p^2 + 8p - 32 = 0 \checkmark$ $4(p^2 + 2p - 8) = 0$ $(p+4)(p-2) = 0$ $p = -4$ or $p = 2$ $p = -4 \checkmark$</p>	<p>1M for squaring 1A for substitution of AB^2 1A for substitution of $(2BC)^2$ ICA for simplification ICA for value of p OR ICA length of BC ICA for substitution ICA squaring ICA simplification ICA value of p (5)</p>
<p>OR $BC = \frac{1}{2} AB$ $= 5 \checkmark$ $5 = \sqrt{(0-4)^2 + (-1-p)^2} \checkmark$ $25 = (0-4)^2 + (-1-p)^2 \checkmark$ $25 = 4^2 + 1^2 + 2p + p^2$ $p^2 + 2p - 8 = 0 \checkmark$ $(p+4)(p-2) = 0$ $p = 2$ or -4 $p = -4 \checkmark$</p>	<p>(5) [19]</p>

QUESTION 3

<p>3.1 is perpendicular to the chord \checkmark</p>	<p>1S for correct conclusion (1)</p>
<p>3.2.1 $AP = 8 \checkmark$ (line from centre of circle to midpoint of chord) \checkmark</p>	<p>IS ; IR (2)</p>
<p>3.2.2 $AO^2 = OP^2 + AP^2$ (Pythagoras) \checkmark $(x+2)^2 = x^2 + 8^2 \checkmark$ $x^2 + 4x + 4 = x^2 + 64 \checkmark$ $4x = 60$ $x = 15$ $\text{radius} = 15 + 2 = 17 \checkmark$</p>	<p>1S/R for Pythagoras 2A for correct substitution ICA for simplification ICA for answer (5)</p>

[8]

QUESTION 4

<p>4.1 Construction: Draw AO and extend to D \checkmark Proof: Let $\hat{B}\hat{A}O = x$ (radii) $OB = OA$ $\therefore \hat{B} = x$ (angles opposite equal sides) \checkmark $\therefore \hat{O}_2 = 2x$ (exterior angle of Δ) \checkmark Similarly let $\hat{C}\hat{A}O = y$ (radii) $OA = OC$ $\therefore \hat{C} = y$ (angles opposite equal sides) $\therefore \hat{O}_1 = 2y$ (exterior angle of Δ) But $\hat{O}_1 + \hat{O}_2 = 2x + 2y \checkmark$ $\therefore \hat{B}\hat{O}C = 2(x+y) \checkmark$ $= 2\hat{B}\hat{A}C$ $= 2\hat{A}$</p>	<p>1M for correct construction 1S/R 1S/R 1 for $\hat{O}_1 = 2y$ 1 for $\hat{O}_1 + \hat{O}_2 = 2x + 2y$ 1 for $\hat{B}\hat{O}C = 2(x+y)$ (6)</p>
--	--

4.2.1(a)	$\hat{C}_6 = \hat{F} = x$ ✓ (FA = CA; angles opposite equal sides) ✓ $\hat{A}_1 = 2x$ ✓ (exterior angle of Δ) ✓	IS ; IR IS ; IR	(4)
4.2.1(b)	$D\hat{O}C = 4x$ ✓ (\angle at centre = 2 x \angle at circumference) ✓	IS ; IR	(2)
4.2.2	DA = CA (both = FA) $\therefore \hat{A}DC = \hat{A}CD$ ✓ (angles opposite equal sides) $= \frac{180^\circ - \hat{A}_1}{2}$ ✓ (sum of \angle s of ΔADC) ✓ $= \frac{180^\circ - 2x}{2}$ $= 90^\circ - x$ $B\hat{C}D = 90^\circ - x + x$ ✓ $= 90^\circ$ $\hat{A}_3 = 90^\circ$ ✓ (exterior \angle of cyclic quad) ✓	IS IS ; IR	(6)

QUESTION 5

5.1.1	$\hat{K}_1 = 90^\circ$ (angle in a semicircle) ✓	IS/R	(1)
5.1.2	$\hat{G} = 180^\circ - (\hat{K}_1 + \hat{H}_1)$ (sum of angles of Δ) $= 180^\circ - (90^\circ + 26^\circ)$ ✓ $= 74^\circ$ $\hat{J} = 180^\circ - \hat{G}$ (opposite \angle 's of cyclic quad) ✓ $= 180^\circ - 74^\circ$ $= 106^\circ$ ✓	IS IS/R	(3)
5.2.1	$\hat{G} = \hat{E}_1 = 28^\circ$ ✓ (angles in the same segment) ✓	I answer	(2)
5.2.2	$\hat{C}_1 = \hat{E}_2 = 64^\circ$ ✓ (exterior \angle of cyclic quad) ✓ $\hat{B} = 180^\circ - (\hat{G} + \hat{C}_1)$ (sum of \angle s of Δ) ✓ $= 180^\circ - (28^\circ + 64^\circ)$ $= 88^\circ$ ✓	IS ; IR IS/R	(4)

[10]

QUESTION 6

6.1	$\hat{Q}_2 = \hat{R}_2 = x$ ✓ (tan-chord-theorem) ✓ $\hat{P}_2 = \hat{R}_2 = x$ ✓ (alt. \angle s; AR \parallel PT) ✓ $\therefore \hat{P}_2 = \hat{Q}_2$ (both = x) PTRQ is a cyclic quadrilateral (converse: angles in the same segment) ✓	IS ; IR IS ; IR IR	(5)
6.2.1	$\hat{Q}_2 = \hat{R}_3 = x$ (angles opposite equal sides) ✓ $P\hat{R}S = 180^\circ - (\hat{R}_2 + \hat{R}_3)$ (QRS is a straight line) $= 180^\circ - 2x$ ✓ $\hat{S} = 180^\circ - (180^\circ - 2x + x)$ (sum of \angle s of ΔPRS) $= x$ ✓	IS/R IS IS	(3)
6.2.1	$\therefore \hat{P}_2 = \hat{S} = x$ (both = x) $\therefore PR = RS$ (sides opposite = \angle s) ✓ But PR = PQ ✓ (2 tangents from same point) ✓ $\therefore PQ = RS$ ✓	IS IS/R IS ; IR IS	(5)
6.2.3	$\hat{Q}_1 = \hat{R}_3 = x$ (tan chord theorem) ✓ $\therefore P\hat{Q}R = 2x$ ✓ ($Q_2 = x$; already proved) $P\hat{Q}R = \hat{T}_3$ (exterior \angle of cyclic quad) ✓ $\therefore \hat{T}_3 = 2x$ $\hat{A}_2 = \hat{Q}_2 + \hat{R}_3$ (exterior angle of Δ) ✓ $= x + x$ $= 2x$ $\hat{T}_3 = \hat{A}_2$ (both = $2x$) ✓ PTS is a tangent to circle TAR (converse: tan chord theorem) ✓	IS/R IS IS/R IS/R IS IR OR IS/R IS/R IS IS/R IS IR	(6)

OR

$\hat{Q}_1 = \hat{R}_3 = x$ (tan chord theorem) ✓
 $\hat{Q}_1 = \hat{R}_1 = x$ (angles in the same segment) ✓
 $T\hat{R}A = \hat{R}_1 + \hat{R}_2 = 2x$ ✓
But $\hat{T}_1 = \hat{R}_2 + \hat{R}_3 = 2x$ (angles in the same segment) ✓
 $\therefore \hat{T}_1 = T\hat{R}A$ (both = $2x$) ✓
 \therefore PTS is a tangent to circle TAR (converse: tan chord theorem) ✓

TOTAL: 100

[19]